

LIGHT SKY[®]

FLY DRAGON LIGHTING EQUIPMENT CO.,LTD

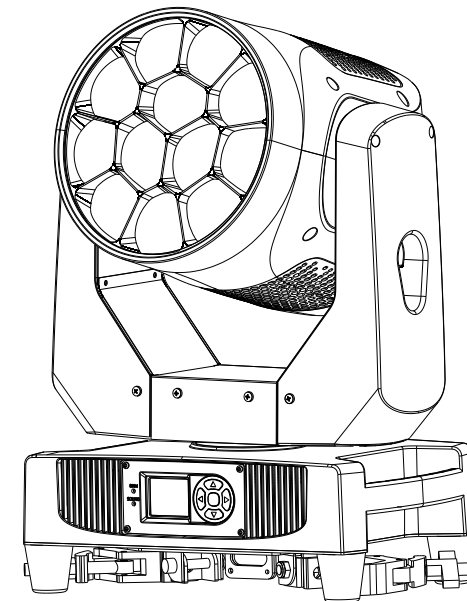

LIGHT SKY[®]

Tel:0086-20-61828288

Fax:0086-20-61828188 Pc:510800

Web:www.lightsky.com.cn

E-mail: flydragon@lightsky.com.cn

asia@lightsky.com.cn

india@lightsky.com.cn

europa@lightsky.com.cn

latinamerica@lightsky.com.cn

middle-east@lightsky.com.cn

american@lightsky.com.cn

Address: No. 43, Yunfeng Road, Xiuquan Street,
Huadu District, Guangzhou, China



LIGHT SKY[®]



PEARL WASH

USER MANUAL

Please read these user manual carefully before use!

Contents

1. Safety information.....	2
2. Technical information.....	4
3. Attachment and body size.....	6
4. Installation and connecting.....	7
5. Control panel.....	9
6. Menu setting.....	10
7. Channel function.....	12
8. Circuit connecting diagram.....	17
9. Cleaning and maintenances.....	18
10.Troubeshooting.....	19
11.Duty exonerative and copyright protection.....	20

Congratulations on choosing our company product! We thank you for your custom.

- ◆ Please note that this product, as all the others in the rich my company range, has been designed and made with total quality to ensure excellent performance and best meet your expectations and requirements.
- ◆ Carefully read this user manual in its entirety and keep it safe for future reference. It is essential to know the information and comply with the instructions given in this manual to ensure the fitting is installed, used and serviced correctly and safely.
- ◆ My company disclaims all liability for damage to the fitting or to other property or persons deriving from installation, use and maintenance that have not been carried out in conformity with this user manual, which must always accompany the fitting.
- ◆ My company reserves the right to modify the characteristics stated in this user manual at any time and without prior notice.

SAFETY INFORMATION



■ This lighting fixture is for professional use only - it is not for household use:

■ Installation

Make sure all parts for fixing the projector are in a good state of repair.

Make sure the point of anchorage is stable before positioning the projector.

The safety chain must be properly hooked onto the fitting and secured to the framework.

When suspending the fixture, ensure that the supporting structure and all hardware used can hold at least 10 times the weight of all the devices they support.



■ Mounting surface and fire protection

Please do not install the luminaire directly on the surface of combustible substances.

Keep all flammable materials at least 20cm away from light fixtures.

There should be no obstructions at least within 20cm of the fan or ventilation on the luminaire.

Do not expose the front glass to sunlight or other strong light sources from any angle.

The lens can focus the sun's rays into the fixture, creating a potential fire hazard.



■ Maximum ambient temperature

$t_a 40^{\circ}\text{C}$

This luminaire is suitable for indoor use, and protective devices are added for outdoor use.

If the ambient temperature (T_a) exceeds 40°C , please do not operate this luminaire.



■ Protection against electrical shock



The ground wire of the power supply system must be effectively grounded (standard EN 60598-1).

In addition, it is recommended that you use an appropriately sized leakage circuit breaker to protect the power cord of the luminaire from being indirectly grounded or short-circuited to ground.

■ Connection to mains supply

Double insulation employed between LV power and control conductors on luminaires.

The bus to which the power supply is connected must be installed by a qualified professional technician.

Check whether the bus frequency and voltage are consistent with the values marked on the label on the luminaire, that is, consistent with the design values of the luminaire.

The label also gives the input power, you need to refer to the calculation of the maximum number of lamps

that can be connected to the wire to avoid overloading.

Do not use the power cord with damaged insulation.

When the power cord of the luminaire is found to be damaged, it must be replaced by the manufacturer or dealer or a qualified person to avoid danger.

When the 110V-power supply is used, the interconnection of the luminaire shall not exceed 5;

when the 220V-power is supplied, the interconnection of the luminaire shall not exceed 10.



t_c 80 °C



■Temperature of the external surface

The maximum temperature that can be reached on the external surface of the fitting, in a thermally steady state, is 80 °C about.

Avoid contact by persons and materials.

Allow the fixture to cool for at least 5 minutes before handling.



■Maintenance

Before starting any maintenance work or cleaning the luminaire, the power supply to the luminaire must be disconnected.



■The light source

The light source in this luminaire should be replaced by the manufacturer or its service agent or a similarly qualified person. Always switch off the power supply before replacing the light source.

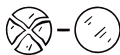

■Protection against explosion

The protective screen, lens or UV screen on the luminaire should be replaced if there is visible damage, that is, damage to the extent of failure, such as cracks or deep marks.



■Protection optical radiation

Never look directly into the light source. You risk injury to your retina, which may induce blindness.



Do not look at LEDs with magnifiers, telescopes, binoculars or similar optical instruments that may concentrate the light output.



The product implementation standard: GB 7000.1-2015 GB7000.217-2008

The products referred to in this manual conform to the European Community Directives to which they are subject:

Low Voltage 2014/35/EU

Electromagnetic Compatibility 2014/30/EU

TECHNICAL INFORMATION

Electrical specifications and connections

- Power supply: Electronic auto-ranging
- Input voltage range: 100-240V 50/60Hz;
- Power rating: 500W PF985;
- Power in connector: Neutrik power
- DMX and RDM data in/out: Locking 3-pin (optional:5-pin XLR)

SOURCE

- Light source: 12×40W RGBL LED
(optional : 12×40W RGBW LED)
- Median Lifetime: 30000 h

OPTICAL SYSTEM

- Beam range: 7-55°
- High precision combination structure, high permeable glass light rod +PMMA lens
- Light output: 45514 lux @3m

DYNAMIC EFFECTS

- Colour mixing mode : RGBL (optional: RGBW)
- Colour rainbow effect with variable speed
- CTO Light output:2200 K - 8000K
- Beam : small degrees beam effect
- Wash : middle and big degrees wash
- FX mode: kaleidoscope effects
- Zoom system: Linear electric zoom
- Lens rotation
Front lens can rotated infinity
- Multi-point control (at least 3 LED chips) effect
- Ring control effect
- Fade in and out gradient effect(at least 3 LED chips)
- Effect macro : Static effect macro functions and
Dynamic effects macro function
- Adjustable speed of effect macro function
- Strobe:Pre-programmed random strobe & pulse effects
(0.5-25Hz/second)
- Dimmer: 0-100% linear adjustment, High resolution
electronic dimming

MOVEMENT

- Pan/ Tilt movement: 540°/270°
- Pan / Tilt Resolution: 2.11°/1.05°
Pan/Tilt : Standard and speed adjustable
- Automatic Pan / Tilt position correction

CONTROL AND PROGRAMMING

- RDM two-way data transmission,Remote reset DMX address
- Display: The display panel adopts a 1.77-inch TFT screen
- Intelligent control: Display board can record
device's using time , showdevice's temperature, channel
data and software version .
- Error alarm: Automatic alarm for fixture failure
- Software upgrade:Upgrade with DMX
- Protocols: DMX-512, RDM
- Control channels: 26CH(Standard), 38CH(extended)
See the channel table for details

THERMAL SPECIFICATION

- Maximum ambient temperature: 40 °C
- Maximum housing temperature: 80 °C
- Minimum operating temperature: -20 °C

MECHANICAL SPECIFICATION

- Structure:The fixture adopted heat-proof engineering
plastics and module pressing alloy materials.
- Integrated folding lamp hook design, more convenient for
disassembly and transportation.
- Ingress protection rating: IP20
- Product dimension: 334mm×218.5mm×479mm
- Box Size (1 sets): 410mm×290mm×575mm
N.W.: 15.3Kg , G.W.: 17.6Kg
- Flycase Size (2 SETS): 660X500X720MM
N.W.: 30.6Kg , G.W.: 62.1Kg

Distance, spot diameter and illumination diagram

55° Lux(fc)	R	332(30)	97(9)	72(6.7)	33(2)
	G	894(83.1)	390(36.2)	215(20)	102(4)
	B	191(17.8)	75(7)	42(3.9)	20(0.1)
	L	1136(105.6)	466(43.3)	256(23.8)	97(5)
	RBGL	2100(195.2)	703(65.3)	398(37)	162(9)

7° Lux(fc)	R	6115(568.3)	2204(204.8)	1381(128.3)	554(51.5)
	G	16711(1553)	6282(583.8)	3928(365.1)	1576(146.5)
	B	3150(292.8)	1194(111)	751(69.8)	302(28.1)
	L	23600(2193)	8935(830.4)	5585(519.1)	2238(208)
	RBGL	45514(4230)	16549(1538)	10343(961.3)	4110(382)

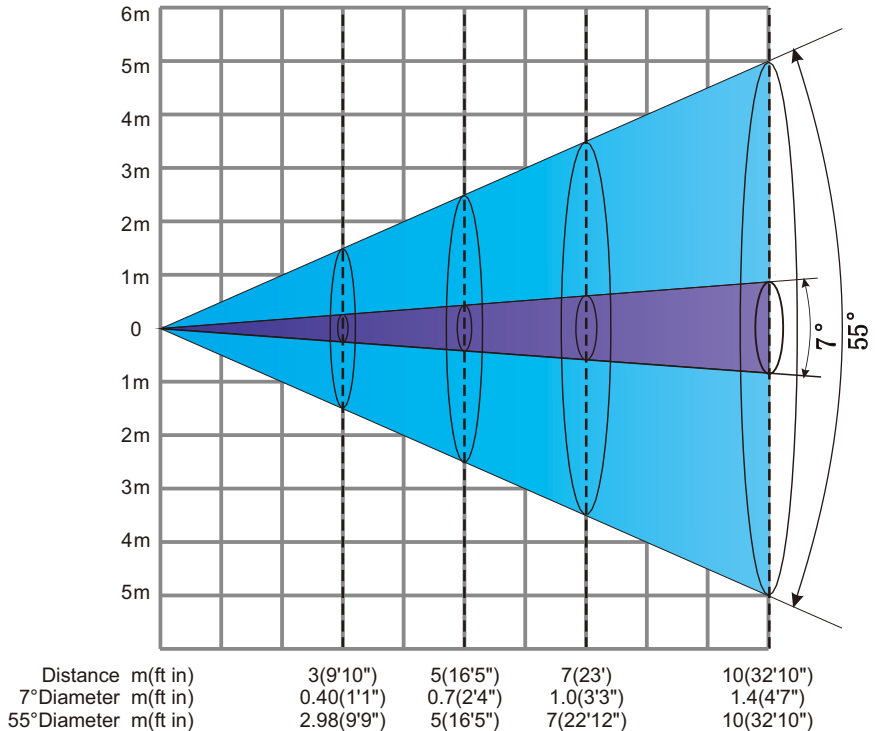

ATTACHMENT AND BODY SIZE

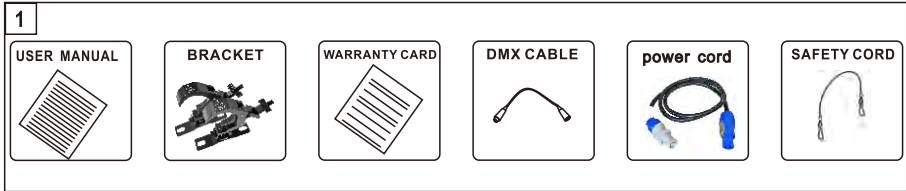

Attachment contents- Fig. 1

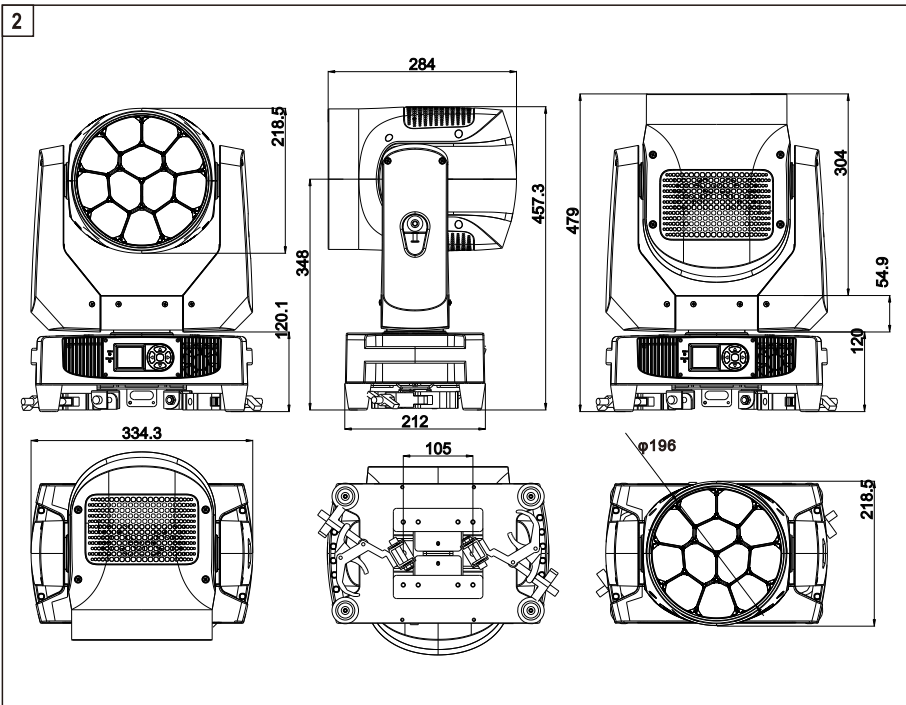

Body Size---Fig 2

INSTALLATION AND CONNECTING

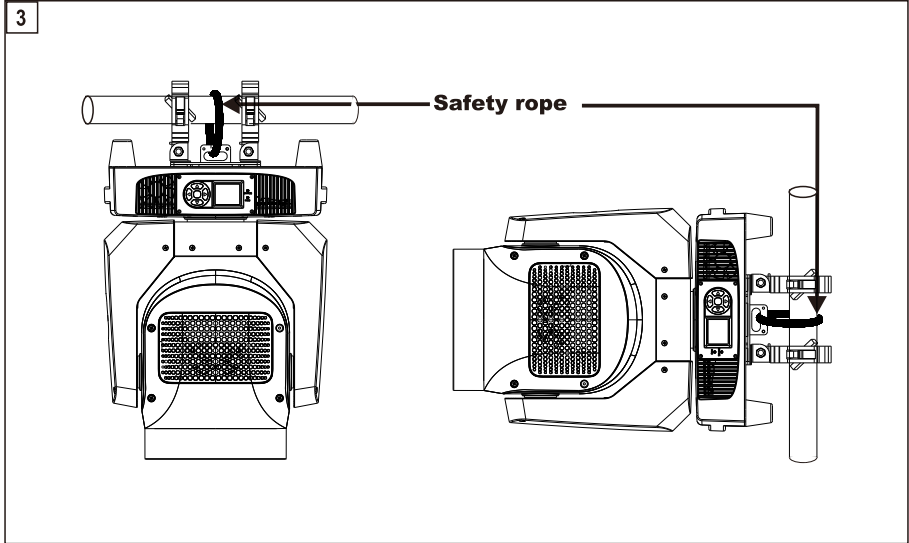

Installing the projector- Fig. 3

The projector can be installed on the floor resting on special rubber feet, on a truss or on the ceiling or wall. **WARNING:**with the exception of when the projector is positioned on the floor, the safety rope must be fitted. This must be securely fixed to the support structure of the projector and then connected to the fixing point at the centre of the base.

4

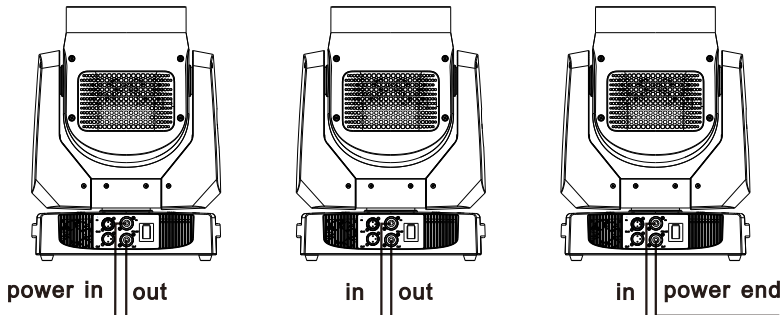

The N terminal is connected with the blue line.

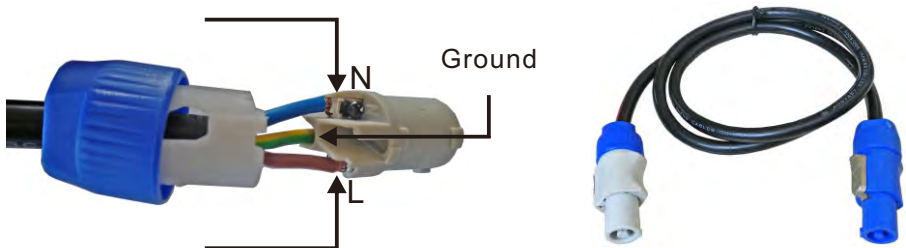

The L terminal is connected with the brown line.

Connecting to the mains supply ---Fig 4

- The stage lighting power supply can not be more than 3pcs pre line, different types of lamps are connected as follows:
- connection to the electricity mains must be carried out by a qualified electrical installer.
- After doing the above operation and making sure all the devices had been installed with natural operate, press the power switch to check whether every -thing is working normally.

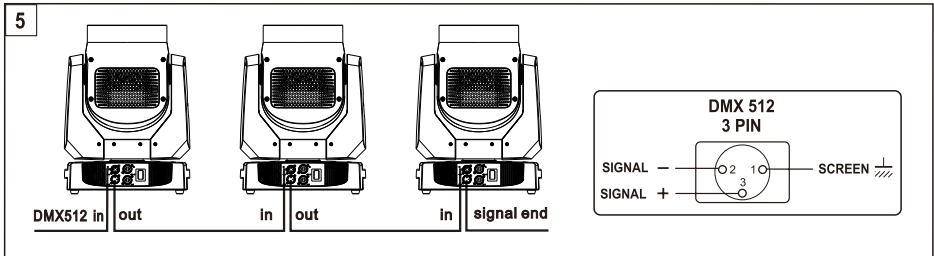

Connecting to the control signal line (DMX) - Fig. 5

- © Please use the round 3 or 5-pin XLR plugs & sockets offered by menu manufacture to connect the first projector's output to the second projector's input and connect the second projector's output to the third projector's input. And in the same way for the rest, eventually connect the last projector's output, all the projectors are together.
- © The projectors' control signal output or input by using the 3 or 5-pin XLR plug and socket. If need to lengthen the communication cable, please make sure the both side of 3 or 5-pin plug is one to one. (one to one, two to two, three to three). Otherwise, the communication cable will be interrupted. The communicate cable is 2-cord screened cable 75Ω resistance with each core is at least a 0.5mm diameter. (**Caution:** All the inside leading wire of 3 or 5-pin XLR plug couldn't touch each other or plinth).
- © Recommend to use the DMX signal terminator for the installation to avoid the electronic noise damage the digital control signal. Simply speaking, DMX terminator is an XLR connector with a 120Ω 1/2W resistor connected across pin 2 and 3. Which is then plugged into the output socket on the last projector in the chain. Refer to the connection.

CONTROL PANEL

6

Up arrowhead: page up
 Down arrowhead: page down
 Left arrowhead: reduce
 Right arrowhead: increase
 Enter: OK function
 Exit: in the choice screen

Press the switch. The projector starts resetting the effects. At the same time, the following information scrolls on the display (please refer to the actual material):

LIGHT SKY®

1. DMX settings

2. Information

3. Personal

4. Manual control

5. Service

Main menu	I menu	II menu	III menu	
	Fan mode	→ Silent Standar Hot.		
	Language	→ Chinese English		
	Display Back.	→ OFF ON		
	Display Dir.	→ Forward Reverse		
Manual →	Channel	→ 1. Pan 000/255 2. Pan Fine 000/255 3. Tilt 000/255 4. Tlit Fine 000/255 5. Function 000/255 6. Dimmer 000/255 7. Dimmer fine 000/255 8. Strobe 000/255 9. Red 000/255 10. Green 000/255 11. Blue 000/255 12. Lemon Green 000/255 13. Color Macro 000/255 14. CCT 000/255 15. Effect Macro 000/255 16. Effect Speed 000/255 17. Effect Fade 000/255 18. Dimmer Back. 000/255 19. Dimmer fine Back. 000/255 20. Strobe Back. 000/255 21. Red Back. 000/255 22. Green Back. 000/255 23. Blue Back. 000/255 24. Lemon Green Back.000/255 25. Zoom 000/255 26. Zoom Rot 000/255		
	Reset	→ PanTilt Zoom module ALL		
Servion →	Adjust	→ Pan 000/255 Tilt 000/255 Zoom 000/255 Zoom Rot. 000/255 Red-1 000/255 Green-1 000/255 Blue-1 000/255 Lemon Green -1 000/255 Green-2 000/255 Green-2 000/255 Blue-2 000/255 Lemon Green-2 000/255 Red-3 000/255 Green-3 000/255 Blue-3 000/255 Lemon Green-3 000/255 Red-4 000/255 Green-4 000/255 Blue-4 000/255 Lemon Green-4 000/255		
		Factory Reset	→ ****	
		Reset timers	→ ****	
		Developer		

CHANNEL FUNCTION(V1.0)

Channel	Value/DMX	percentage	Function	Note
26CH				
1			PAN	
	0-255		0%...100%	
2			PAN FINE	
	0-255		0%...100%	
3			TILT	
	0-255		0%...100%	
4			TILT	
	0-255		0%...100%	
5			FUNCTION	
	0-127		No Fuction	
	128-255		Reset	
6			DIMMER	
	0-255		Dimmer 0%...100%	
7	0 127		DIMMER FINE	
	128-255		Dimmer 0%...100%	
			Strobe	
8	0 3		Light ON	
	4 103		Strobe Frequency	
	104 107		Light ON	
	108 207		Pulsation	
	208 212		Light ON	
	213 225		Random Slow	
	226 238		Random Medium	
	239 251		Random Fast	
	252 255		Light ON	
9			RED	
	0-255		0 100% Red dimmer from dark to bright	
10			GREEN	
	0-255		0 100% green dimmer from dark to bright	
11			BLUE	
	0-255		0 100% Blue dimmer from dark to bright	
12			Lime Green	
	0-255		0 100% Lime Green dimmer from dark to bright	
13			Color Macro	
	0-255		Color Macro	
			CCT	
14	0 9		No Fuction	
	10 19		2200K	
	20 29		2800K	
	30 39		3000K	
	40 49		3200K	
	50 59		4000K	
	60 69		4800K	
	70 79		5600K	
	80 89		6000K	
	90 99		7000K	
	100 255		8000K	

Channel	Value/DMX	percentage	Function	Note
15			Effect Macro	
	0 10		No Fuction	
	11 20		Macro1	
	21 30		Macro2	
	31 40		Macro3	
	41 50		Macro4	
	51 60		Macro5	
	61 70		Macro6	
	71 80		Macro7	
	81 90		Macro8	
	91 100		Macro9	
	101 110		Macro10	
	111 120		Macro11	
121 130		Macro12		
131 255		No Fuction		
16			Effect Speed	
	0 125		Macro Speed from slow to fast	
	126 129		Macro Stop	
	130 255		Macro Speed from fast to slow	
17			Effect Fade	
	0-255		0 100%	
18			Dimmer Back	
	0-255		Dimmer Back 0%...100%	
19			Dimmer Fine Back	
	0-255		Dimmer Fine Back 0%...100%	
20			Strobe Back	
	0-255		Macro Speed from slow to fast	
21			Red Back	
	0-255		0 100% Red dimmer from dark to bright	
22			Green Back	
	0-255		0 100% Green dimmer from dark to bright	
23			Blue Back	
	0-255		0 100% Blue dimmer from dark to bright	
24			Lime green	
	0-255		0-100% lemon green from dark to light to dark	
25			Zoom	
	0-255		0 100% Mix to Max	
26			Zoom ROTA	
	0 100		0 100% Run_mode_normal 0°-360°	
	101 190		Cw Rotation	
	191 192		Run_mode_stop	
	193 255		Ccw Rotation	

Channel	Value/DMX	percentage	Function	Note
38CH				
1			PAN	
	0-255		0%...100%	
2			PAN FINE	
	0-255		0%...100%	
3			TILT	
	0-255		0%...100%	
4			TILT FINE	
	0-255		0%...100%	
5			FUNCTION	
	0 127		No Fuction	
	128-255		Reset	
6			DIMMER	
	0-255		Dimmer 0%...100%	
7			DIMMERFINE	
	0-4		Dimmer Fine 0%...100%	
8			Strobe	
	0 3		Light ON	
	4 103		Strobe Frequency	
	104 107		LightON	
	108 207		Pulsation	
	208 212		LightON	
	213 225		Random Slow	
	226 238		Random Medium	
	239 251		Random Fast	
252 255		LightON		
9			RED 1	
	0-255		0 100% Red dimmer from dark to bright	
10			GREEN 1	
	0-255		0 100% green dimmer from dark to bright	
11			BLUE 1	
	0-255		0 100% Blue dimmer from dark to bright	
12			Lime GREEN 1	
	0-255		0 100% Lime green dimmer from dark to bright	
13			RED 2	
	0-255		0 100% Red dimmer from dark to bright	
14			GREEN2	
	0-255		0 100% green dimmer from dark to bright	
15			BLUE 2	
	0-255		0 100% Blue dimmer from dark to bright	
16			Lime GREEN 2	
	0-255		0 100% Lime green dimmer from dark to bright	
17			RED 3	
	0-255		0 100% Red dimmer from dark to bright	
18			GREEN 3	
	0-255		0 100% green dimmer from dark to bright	
19			BLUE 3	
	0-255		0 100% Blue dimmer from dark to bright	

Channel	Value/DMX	percentage	Function	Note
20			Lime GREEN 3	
	0-255		0 100% Lime green dimmer from dark to bright	
21			RED 4	
	0-255		0 100% Red dimmer from dark to bright	
22			GREEN 4	
	0-255		0 100% green dimmer from dark to bright	
23			BLUE 4	
	0-255		0 100% Blue dimmer from dark to bright	
24			Lime GREEN 4	
	0-255		0 100% Lime green dimmer from dark to bright	
25			Color Macro	
	0-255		Color Macro	
26			CCT	
	0 9		No Fuction	
	10 19		2200K	
	20 29		2800K	
	30 39		3000K	
	40 49		3200K	
	50 59		4000K	
	60 69		4800K	
	70 79		5600K	
	80 89		6000K	
90 99		7000K		
100 255		8000K		
27			Effect Macro	
	0 10		No Fuction	
	11 20		Macro1	
	21 30		Macro2	
	31 40		Macro3	
	41 50		Macro4	
	51 60		Macro5	
	61 70		Macro6	
	71 80		Macro7	
	81 90		Macro8	
	91 100		Macro9	
	101 110		Macro10	
	111 120		Macro11	
121 130		Macro12		
131 255		No Fuction		
28			Effect Speed	
	0 125		Macro Speed from slow to fast	
	126 129		Macro Stop	
	130 255		Macro Speed from fast to slow	
29			Effect Fade	
	0-255		0 100%	
30			Dimmer Back	
	0-255		Dimmer Back 0%...100%	
31			Dimmer Fine Back	
	0-255		Dimmer Fine Back 0%...100%	

Channel	Value/DMX	percentage	Function	Note
32			Strobe Back	
	0-255		Macro Speed from slow to fast	
33			Red Back	
	0-255		0 100% Red dimmer from dark to bright	
34			Green Back	
	0-255		0 100% Green dimmer from dark to bright	
35			Blue Back	
	0-255		0 100% Blue dimmer from dark to bright	
36			Lime green Back	
	0-255		0 100% Lime green dimmer from dark to bright	
37			Zoom	
	0-255		0 100% Mix to Max	
38			Zoom ROTA	
	0 100		0 100% Run_mode_normal 0° 360°	
	101 190		Cw Rotation	
	191 192		Run_mode_stop	
	193 255		Ccw Rotation	

Circuit connecting diagram

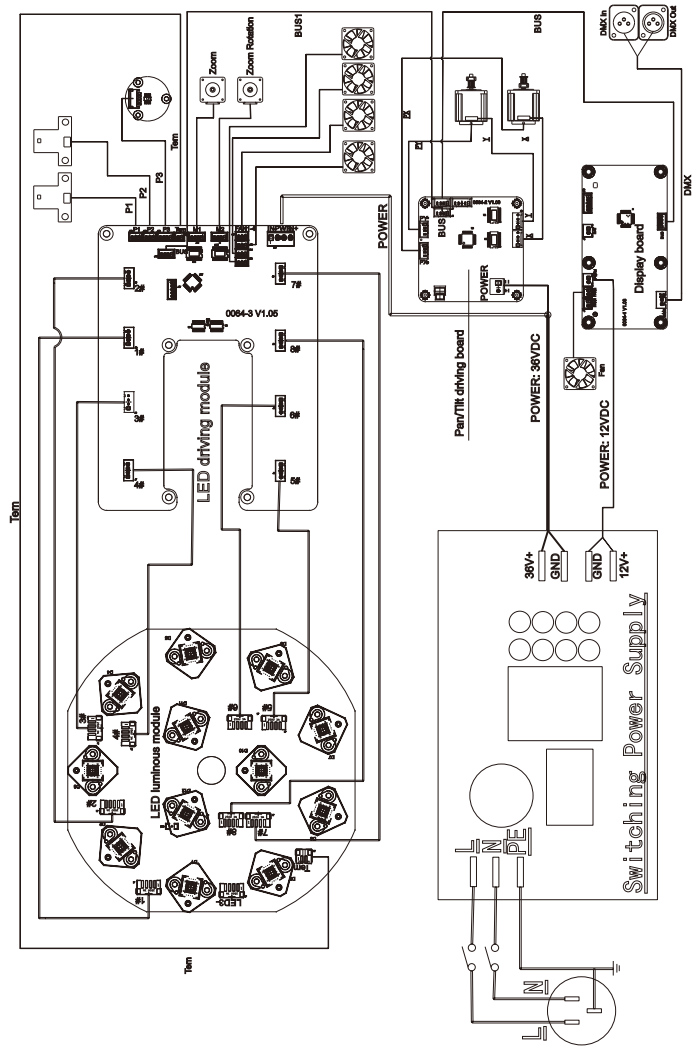

CLEANING AND MAINTENANCES

- 1. In order to ensure the projector could work normally. It should be kept clean always .
The lens should also be regularly cleaned to maintain an optimum light output.
Do not use any type of solvent on lens. It will damage the projector.

- 2. Suggestion: The continue usage of the light don't exceed 4 hours. Or it will shorter the usage of the lamp. Please use the alternative operation to solve this problem.
The fixture power ON time is best not over 48 hours, or it would generate lamp protection procedure.

- 3. Please disconnect the power supply when begin to maintenance take down the light.
Please let the parts cool down 10 minute at least then begin to install.

- 4. Please inspect the lens or other moving parts timing and keep them clear and static.
If find anything damaged or looseness must change a lamp or fix the lamp in order to avoid the accident.
Please check the machanical parts is jamging. After cleaning, please add some temperature -durable juice.

- 5. The light use the strong cool system. It is easy for the dirty to be colleted. Please do clear the hot-sak one time two week at least.

- 6. After you use the light, please check the intake place whether there are some wastepaper, please clean it up, or the windmill will break down and causing fire.

CAUTION!

Disconnect from mains before starting maintenance operation.

TROUBLESHOOTING

It is recommended some solution for some normal trouble shooting. Any inextricability problems should always be handling by the professional person. Disconnect the power supply before maintenance the light.

■ LED off / LED:

1. Please check if install the suitable voltage.
2. Please check whether the led will reach the end of their life can explode; please replace a same description led.
3. Please check if the power supply is enough.
4. Please check whether the DMX 512 controller pass the "turn on" order.

■The light couldn't accept the control order:

1. Please check the start code address and the function option are correct.
2. Please check whether the communicate control cable is on good connection or the cable is too long or interrupt.
3. Please check the control system is not valid, check the signal amplifier of chain connected is valid.
4. Please check whether the communicate cable is too long or the other equipment is mutually conjugate.
5. Please arrange the wire well, shorter the signal cable, put the high voltage cable and low voltage cable separately.
6. Add the signal amplify isolator.
7. Signal cable is used the excellent screening doublet (Resistance 75 OHM) .
8. The end of the light end and the end resistance.

■The light can't move:

1. Please check if the power supply is suitable for the light voltage data.
2. Please check the light if they are deformation, inside parts is broken, become wet etc will lead the loose contact.
3. Please check the if the inside lead wire and the connector is loose.
4. Please check the electric parts(such as the transformer, PCB board, contrller) is short-circuit or burn down.

■

On working, the pan & tilt couldn't work normally:

1. Please check according to the above step by step.
2. Please check the belt of the X.Y is broken.
3. Please check the X/Y direction data to the receiver is damage.
4. Re-projector reset.

DUTY EXONERATIVE AND COPYRIGHT PROTECTION

- The lamp belongs to consumption products that is not guarantee to keep it in good repair.
- Any products broken that didn't according to the instruction is not guarantee to keep it in good repair.
- Any products broken that didn't according to the instruction is not guarantee to keep it in good repair.
- No authorize can't copy.
- The information in this manual may be changed in the future,the company reserve the right to changethe data without any advise.