



SolaSpot Pro CMY

User Manual

© High End Systems Inc., 2017, All Rights Reserved

Information and specifications in this document are subject to change without notice. High End Systems assumes no responsibility or liability for any errors or inaccuracies that may appear in this manual.

Trademarks used in this text:

High End Systems is a registered trademark. Wholehog, intellaspot, Internal Effects, the High End Systems globe logo, and the Hog logo are trademarks of High End Systems, Belden is a registered trademark of Belden, Inc.

Other trademarks and trade names may be used in this document to refer to either the entities claiming the marks and names or their products. High End Systems disclaims any proprietary interest in trademarks and trade names owned by others.

HIGH END SYSTEMS



an **ETC.** Company



SolaSpot Pro CMY User Manual

Version 1.1

July, 2015

Contact Information

U.S. and the Americas

Sales Department High End Systems
2105 Gracy Farms Lane
Austin, TX 78758 USA
voice: 512.836.2242
fax: 512.837.5290
Toll Free: 800.890.8989

Customer Service High End Systems
2105 Gracy Farms Lane
Austin, TX 78758 USA
voice: 800.890.8989
fax: 512.834.9195
toll free: 800.890.8989

World Wide Web: <http://www.highend.com>

Product Modification Warning

High End Systems products are designed and manufactured to meet the requirements of United States and International safety regulations. Modifications to the product could affect safety and render the product non-compliant to relevant safety standards.

Mise En Garde Contre La Modification Du Produit

Les produits High End Systems sont conçus et fabriqués conformément aux exigences des règlements internationaux de sécurité. Toute modification du produit peut entraîner sa non conformité aux normes de sécurité en vigueur.

Produktmodifikationswarnung

Design und Herstellung von High End Systems entsprechen den Anforderungen der U.S. Amerikanischen und internationalen Sicherheitsvorschriften. Abänderungen dieses Produktes können dessen Sicherheit beeinträchtigen und unter Umständen gegen die diesbezüglichen Sicherheitsnormen verstoßen.

Avvertenza Sulla Modifica Del Prodotto

I prodotti di High End Systems sono stati progettati e fabbricati per soddisfare i requisiti delle normative di sicurezza statunitensi ed internazionali. Qualsiasi modifica al prodotto potrebbe pregiudicare la sicurezza e rendere il prodotto non conforme agli standard di sicurezza pertinenti.

Advertencia De Modificación Del Producto

Los productos de High End Systems están diseñados y fabricados para cumplir los requisitos de las reglamentaciones de seguridad de los Estados Unidos e internacionales. Las modificaciones al producto podrían afectar la seguridad y dejar al producto fuera de conformidad con las normas de seguridad relevantes.

Important Safety Information

Instructions pertaining to continued protection against fire, electric shock, and injury to persons are found throughout this manual. Please read all instructions prior to assembling, mounting, and operating this equipment.

The following international caution and warning symbols appear in margins throughout this manual to highlight messages.



This symbol appears adjacent to Caution messages. Not heeding these messages could result in personal injury and/or damage to equipment.



This symbol appears adjacent to high voltage warning messages. Not heeding these messages could result in serious personal injury.



This symbol cautions against mounting the fixture on or near a flammable surface.



This symbol indicates that, while operating, equipment surfaces may reach very high temperatures. Allow the fixture to cool before handling.

Warranty Information

Limited Warranty

Unless otherwise stated, your product is covered by a one year parts and labor limited warranty. Dichroic filters and LithoPatterns® high resolution glass gobos are not guaranteed against breakage or scratches to coating. It is the owner's responsibility to furnish receipts or invoices for verification of purchase, date, and dealer or distributor. If purchase date cannot be provided, date of manufacture will be used to determine warranty period.

Returning an Item Under Warranty for Repair

It is necessary to obtain a Return Material Authorization (RMA) number from your dealer or point of purchase BEFORE any units are returned for repair. The manufacturer will make the final determination as to whether or not the unit is covered by warranty.

A fixture must be returned in its original packaging. Any other parts returned to High End Systems must be packaged in a suitable manner to ensure the protection of such product unit or parts, and such package shall be clearly and prominently marked to indicate that the package contains returned Product units or parts and with an RMA number. Accompany all returned Product units or parts with a written explanation of the alleged problem or malfunction. Ship returned Product units or parts to: 2105 Gracy Farms Lane, Austin, TX 78758 USA.

Note: *Freight Damage Claims are invalid for fixtures shipped in non-factory boxes and packing materials.*

Freight

All shipping will be paid by the purchaser. Items under warranty shall have return shipping paid by the manufacturer only in the Continental United States. Under no circumstances will freight collect shipments be accepted. Prepaid shipping does not include rush expediting such as air freight. Air freight can be sent customer collect in the Continental United States.

REPAIR OR REPLACEMENT AS PROVIDED FOR UNDER THIS WARRANTY IS THE EXCLUSIVE REMEDY OF THE CONSUMER. HIGH END SYSTEMS, INC. MAKES NO WARRANTIES, EXPRESS OR IMPLIED, WITH RESPECT TO ANY PRODUCT, AND HIGH END SPECIFICALLY DISCLAIMS ANY WARRANTY OF MERCHANTABILITY OR FITNESS FOR A PARTICULAR PURPOSE. HIGH END SHALL NOT BE LIABLE FOR ANY INDIRECT, INCIDENTAL OR CONSEQUENTIAL DAMAGE, INCLUDING LOST PROFITS, SUSTAINED OR INCURRED IN CONNECTION WITH ANY PRODUCT OR CAUSED BY PRODUCT DEFECTS OR THE PARTIAL OR TOTAL FAILURE OF ANY PRODUCT REGARDLESS OF THE FORM OF ACTION, WHETHER IN CONTRACT, TORT (INCLUDING NEGLIGENCE), STRICT LIABILITY OR OTHERWISE, AND WHETHER OR NOT SUCH DAMAGE WAS FORESEEN OR UNFORESEEN.

Warranty is void if the product is misused, damaged, modified in any way, or for unauthorized repairs or parts. This warranty gives you specific legal rights, and you may also have other rights which vary from state to state.

Patents

This product may use one or more of the following patents: US 4,392,187; US 4,602,321; US 4,688,161; US 4,701,833; US 4,709,311; US 4,779,176; US 4,800,474; US 4,962,687; US 4,972,306; US 4,980,806; US 5,010,459; US 5,031,078; US 5,073,847; US 5,078,039; US 5,186,536; US 5,209,560; US 5,278,742; US 5,282,121; US 5,307,295; US 5,329,431; US 5,331,822; US 5,367,444; US 5,402,326; US 5,414,328; US 5,426,576; US 5,430,629; US 5,432,691; US 5,454,477; US 5,455,748; US 5,502,627; US 5,506,762; US 5,515,254; US 5,537,303; US 5,545,951; US 5,588,021; US 5,590,954; US 5,590,955; US 5,640,061; US 5,647,662; US 5,691,886; US 5,702,082; US 5,728,994; US 5,758,955; US 5,758,956; US 5,769,527; US 5,769,531; US 5,774,273; US 5,788,365; US 5,794,881; US 5,795,058; US 5,798,619; US 5,806,951; US 5,812,596; US 5,823,661; US 5,825,548; US 5,828,485; US 5,829,868; US 5,857,768; US 5,882,107; US 5,921,659; US 5,934,794; US 5,940,204; US 5,945,786; US 5,953,151; US 5,953,152; US 5,969,485; US 5,980,066; US 5,983,280; US 5,984,248; US 5,986,201; US 6,011,662; US 6,029,122; US 6,048,080; US 6,048,081; US 6,054,816; US 6,057,958; US 6,062,706; US 6,079,853; US 6,126,288; US 6,142,652; US 6,142,653; US 6,172,822; US 6,175,771; US 6,188,933; US 6,208,087; US 6,219,093; US 6,220,730; US 6,241,366; US 6,249,091; US 6,255,787; US 6,256,136; US 6,261,636; US 6,278,542; US 6,278,545; US 6,278,563; US 6,288,828; US 6,326,741; US 6,327,103; US 6,331,756; US 6,346,783; US 6,421,165; US 6,430,934; US 6,459,217; US 6,466,357; US 6,502,961; US 6,515,435; US 6,523,353; US 6,536,922; US 6,538,797; US 6,545,586; US 6,549,324; US 6,549,326; US 6,563,520; US 6,565,941; US 6,570,348; US 6,575,577; US 6,578,991; US 6,588,944; US 6,592,480; US 6,597,132; US 6,600,270; US 6,601,974; US 6,605,907; US 6,617,792; US 6,621,239; US 6,622,053; US 6,635,999; US 6,648,286; US 6,664,745; US 6,682,031; US 6,693,392; US 6,696,101; US 6,719,433; US 6,736,528; US 6,771,411; US 6,775,991; US 6,783,251; US 6,801,353; US 6,812,653; US 6,823,119; US 6,865,008; US 6,866,390; US 6,866,402; US 6,866,451; US 6,869,193; US 6,891,656; US 6,894,443; US 6,919,916; US 6,930,456; US 6,934,071; US 6,937,338; US 6,955,435; US 6,969,960; US 6,971,764; US 6,982,529; US 6,988,805; US 6,988,807; US 6,988,817; US 7,000,417; US 7,011,429; US 7,018,047; US 7,020,370; US 7,033,028; US 7,048,838; US 7,055,963; US 7,055,964; US 7,057,797; US 7,073,910; US 7,078,869; US 7,092,098; US 7,119,902; US 7,161,562; US 7,175,317; US 7,181,112; US 7,206,023; US 7,210,798; US D347,113; US D350,408; US D359,574; US D360,404; US D365,165; US D366,712; US D370,080; US D372,550; US D374,439; US D377,338; US D381,740; US D409,771; AT E169413; CA 2142619; CA 2145508; CA 2245842; DE 22588.4-08; DE 621495; DE 655144; DE 69320175.4; DE 69322401.0; DE 69331145.2; DE 69525856.7; DE 69734744.3; DE 797503; DK 0655144; DK 1447702; EP 0475082; EP 0621495; EP 0655144; EP 0662275; EP 0767398; EP 0797503; EP 0969247; EP 1447702; ES 0621495; FR 0621495; FR 0655144; FR 0662275; FR 1447702; GB 2043769B; GB 2055842B; GB 2283808B; GB 2290134B; GB 2291814B; GB 2292530B; GB 2292896B; GB 2294909B; GB 2295058B; GB 2303203B; GB 2306887B; GB 2307036B; GB 2316477B; IE 0621495; IT 034244BE; 2005; IT 0621495; IT 0655144; JP 3495373; JP 3793577; NL 0621495; NL 0797503; NL 0969247; UK 0621495; UK 0655144; UK 0662275; UK 0797503; UK 0969247; UK 1447702;

Table of Contents

SolaSpot Pro CMY User Manual	i
Contact Information	ii
Product Modification Warning	iii
Important Safety Information	iv
Warranty Information	v
Limited Warranty	v
Returning an Item Under Warranty for Repair	v
Freight	v
Patents	vi
Chapter 1: Product Overview	
Features	1
Operation	1
Effects	2
Construction	2
Specifications	3
Mechanical Specifications	3
Lithopattern Specifications	3
Electrical Specifications	4
Environmental Specifications	4
Cables and Connectors	4
Fixture Components	5
Related Products and Accessories	6
Chapter 2: SolaSpot Pro CMY Setup and Configuration	
Unpacking the Fixture	7
Pan and Tilt Locking	7
Installing a Power Cord Cap	8
Installing a Line Cord Cap - U.K. Only	8
Vatic Fitter Heads Information - Danmark	8
Mounting the Fixture	9
Mounting the Fixture Upright	9
Truss Mounting	9
Linking SolaSpot Pro CMY Fixtures	11
Cable Connectors	11
Connecting to the Link	12

Configuring SolaSpot Pro CMY for DMX Control	14
Setting a Start Channel in Battery Mode	14
Powering On the Fixture	15
Shutting Down the Fixture	15
Chapter 3: Menu System	
Menu System Overview	17
Navigation Basics	18
Battery Operation	18
Exiting Battery Mode.....	18
SolaSpot Pro CMY Menu Map	19
Menu System Options	22
Address Menu	22
Setting a Start Channel.....	22
Determining DMX Start Channel Assignment	23
Information Menu	24
Time Info	24
Values Display	25
Head Temperature.....	25
Software Version.....	25
Set Menu	26
Status Options	26
Service Setting	27
Display Setting	28
Temp C/F	28
Reset Default.....	28
Test Options Menu	30
Homing the Fixture.....	30
Manual Ctrl.....	30
Calibration.....	31
Preset Menu	31
Battery Menu	31

Chapter 4: Preset Programming

Preset Programming Overview	33
Navigating to the Preset Menu	33
Master and Slave	34
Preset Menu	35
Playback Settings	35
Automatic Program Run	35
Set to Slave	35
DMX Control	35
Music Control	35
Edit Scenes	36
Edit Scene Parameters	36
Edit Scene Time	36
Set Fade Time	36
Set Input by Out	37
Edit Program	37
Select Program	38
Scenes Input	38

Chapter 5: DMX Programming

DMX Programming Overview	39
Full Speed versus MSpeed Control	39
16-bit Functionality	39
DMX Programming Options	39
Programming with a DMX Console	39
SolaSpot Pro CMY DMX Protocol	40
Pan and Tilt Parameters	41
Color Parameters	41
Color Mix Function	41
Cyan, Magenta, and Yellow	41
Static Color	Function 42
Static Color Position	43
Gobo Wheel Parameters	44
Static Gobo Wheel Parameters	44
Static Gobo Function	44
Static Gobo Position	45

Rotating Gobo Wheel Parameters	46
Rotating Gobo Function	46
Rotating Gobo Position	47
Rotating Gobo Rotate Function	48
Rotating Gobo Rotate	48
Prism Parameters	49
Prism Function	49
Prism Rotate	49
Frost Parameter	50
Focus Parameters	50
Zoom Parameters	50
Iris Parameter	50
Shutter Parameters	51
Shutter Function	51
Shutter	51
Dim	51
MSpeed (Motor Speed)	52
Control	52
Indigo Highlighter	53
Indigo Highlighter Function	53
Indigo Highlighter Dim	53
 Chapter 6: General Maintenance and Troubleshooting	
Safety Considerations	55
Maintenance	55
Replacing Rotating Gobos	56
Cleaning the Fixture	57
Troubleshooting Error Messages	58
PAN- movement Er	58
TILT- movement Er	58
Gobo Wheel 1 Er	58
Gobo Wheel 2 Er	58
Color wheel Er	58
Zoom Er	59
Focus Er	59
 Appendix A: MSpeed Conversion Table	 61

Chapter 1:

Product Overview

This chapter describes the features and specifications of the SolaSpot Pro CMY fixture along with a list of related products and accessories.

A 13,000+ lumen output from a 320 w LED source makes the SolaSpot Pro CMY the brightest and the most efficient LED spot available.

Lighting designers don't need to make tradeoffs between the quality of white and color, or be concerned about the quantity of output. The SolaSpot Pro CMY LED, provides an LED fixture that can replace existing 700w and some 800w arc fixtures. All this coupled with the long life of the LED source.

Alongside yet another industry first when it comes to LED and CMY, are features like Linear CTO, 2 gobo wheels, a fixed color wheel, incredibly quick zoom and focus, a prism, iris and frost.

Including High End System's patented lens defogger, SolaSpot Pro CMY is an innovative step towards the future.

Features

- LED light engine with 13,000 lumen bright white output with even beam field
- No lamp to change, LED source lasts over 30,000 hours
- CMY Color Mixing with additional fixed color and gobo wheels
- Linear CTO
- Patented Lens Defogger
- Lowest Price in Class
- Small Footprint

Operation

- Pan Range: 540° (optional 630°)
- Tilt Range: 265°
- 35 DMX channels includes 16-bit control of Movement, Focus, Zoom and Dim functions
- DMX/RDM connectors: 5-pin XLR, 3-pin XLR
- Onboard menu system for configuration and preset programming
- 12° – 40° Zoom
- LED strobe
- Fast mechanical iris

- Smooth electronic dimming
- Stand alone operation with Master/Slave function, sound activated via built in microphone.
- Adjustable Movement Speed
- Scan position memory to auto reposition unit after unexpected movement
- Display can be changed 180° reverse to fit for different installation position.
- Strobe/shutter: High speed shutter, 0-13 Hz or random strobe
- Rechargeable Back up Battery for Display, no need external power supply, enable users to enter display menu for address setting or access other functions setting.
- Software-upload by optional accessory via DMX line

Effects

- Fixed Color wheel with seven positions plus open
- Fixed Gobo Wheel with seven patterns plus open
- Rotating Gobo Wheel with six rotating lithopatterns
- Prism and prism rotating , with 16 prism macros
- Iris from 5%~100% with pulse iris effect.
- Stepless frost, 0%~100% linear change frost
- Indigo Highlighter LED output

Construction

- High resolution micro-stepping motor control for smooth motion at all speeds
- Fast, smooth, and quiet yoke movement
- Full color LCD graphic display and touch-keyboard
- 3-pin and 5-pin XLR/RDM connectors
- Roadcase
- ETL/UL and CE compliance

Specifications

Mechanical Specifications

Fixture Dimensions: 389mm x 319.8mm x 715.5mm (15.3in x 12.6in x 28.1in)

Fixture Weight: 29.5 kg (65 lbs)

Shipping Weight: 66 kg (145.5 lbs)

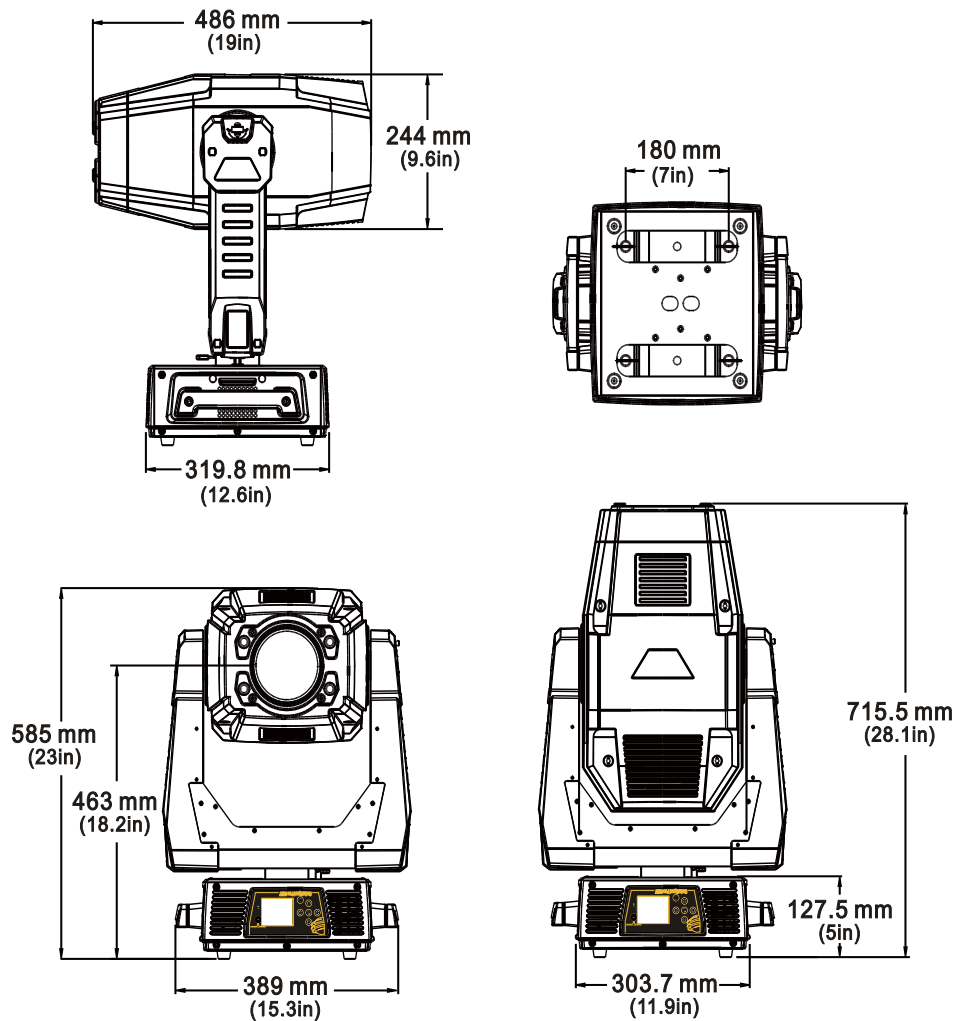

Lithopattern Specifications

Diameter: 28.75 mm (1.132 in)

Maximum image area: 23.4 mm (.921 in)

Electrical Specifications

Fixture Rated Power: 480 W

Power consumption: AC 100V–240V; 50Hz/60Hz; 4.8-2.0A



Warning: Class I equipment - For continued protection against electric shock connect this equipment to an earthed (grounded) power source only.

This equipment for connection to branch circuit having a maximum overload protection of 20 A.

Environmental Specifications

Maximum ambient temperature: 45° C (113° F)

Maximum exterior surface temperature: 110° C (230° F)

Minimum distance to lighted object: .5 m (1.6 ft)

Minimum distance to flammable objects: .5 m (1.6 ft)



Caution: Do not mount on a flammable surface. Not for residential use. Use in dry locations only.



Caution: Class 2 LED product. LED Radiation. Do not stare into beam.

Caution: The fixture should be positioned so that prolonged staring into the fixture at a distance closer than 3 meters is not expected.



Cables and Connectors

Belden® 3107A or equivalent (meets specifications for EIA RS-485 applications) with the following characteristics:

- Two twisted pairs plus a shield
- maximum capacitance between conductors - 30 pF/ft.
- maximum capacitance between conductor and shield - 55 pF/ft.
- maximum resistance of 20Ω / 1000 ft.
- nominal impedance 100-140 Ω

Fixture Components

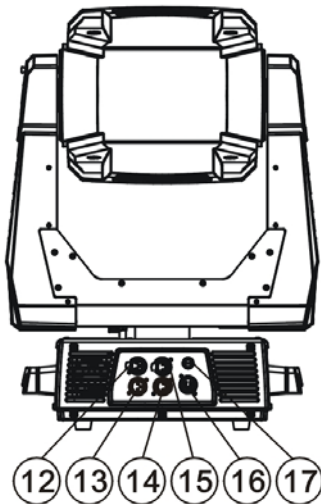
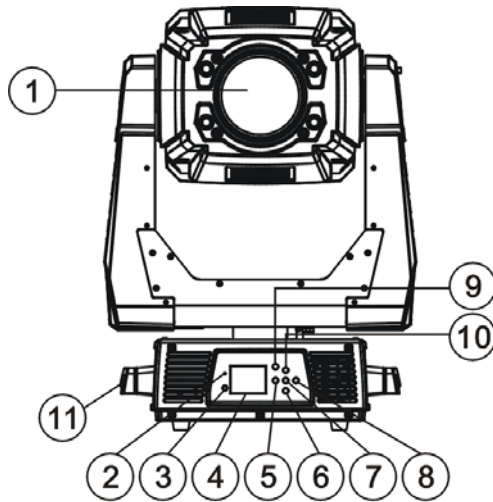

1. Lens
2. Display
3. Battery Display button
4. Microphone
5. Left-button
6. Down-button
7. Right-button
8. Mode/Esc
9. Up-button
10. ENTER-button
11. Handle
12. 5-pin DMX out
13. 5-pin DMX in
14. 3-pin DMX out
15. 3-pin DMX in
16. Power supply
17. Fuse

Related Products and Accessories

Name	Part Number
SolaSpot Pro CMY fixed color wheel dichroic filters	Contact Customer Service: 2105 Gracy Farms Lane Austin, TX 78758 USA voice:800.890.8989 fax: 512.834.9195
Heavy duty 5-pin XLR cable (10')	55050017
Heavy duty 5-pin XLR cable (25')	55050018
Heavy duty 5-pin XLR cable (50')	55050019
Heavy duty 5-pin XLR cable (100')	55050020
Galvanized safety cable	12040001

Chapter 2: SolaSpot Pro CMY

Setup and Configuration

Installation of your SolaSpot Pro CMY fixture includes mounting, connecting to power, DMX linking and configuration.

Use the following steps to set up and configure your fixture:

1. **Unpack the fixture.**
2. **Install power cord cap for your location.**
3. **Mount the fixture upright or suspended from a standard truss.**
4. **Connect the fixture to a DMX controller via DMX cabling.**
5. **Configure the fixture for DMX control.**

Unpacking the Fixture

The SolaSpot Pro CMY fixture ships in packaging specifically designed to protect the product during transport. When unpacking, inspect the fixture for physical damage to components. High End Systems® assumes no responsibility for products that are damaged during transport. Return a product for repair in its original packaging.

Before sending anything to the factory, call your High End Systems dealer/distributor for a Return Material Authorization (RMA) number. The factory cannot accept any goods shipped without an RMA number.

Pan and Tilt Locking

The SolaSpot Pro CMY fixture ships with pan and tilt latches locked. You can unlock/adjust these latches to stabilize the fixture for mounting.

Note: *Always disengage Pan and Tilt locks before operating the fixture.*

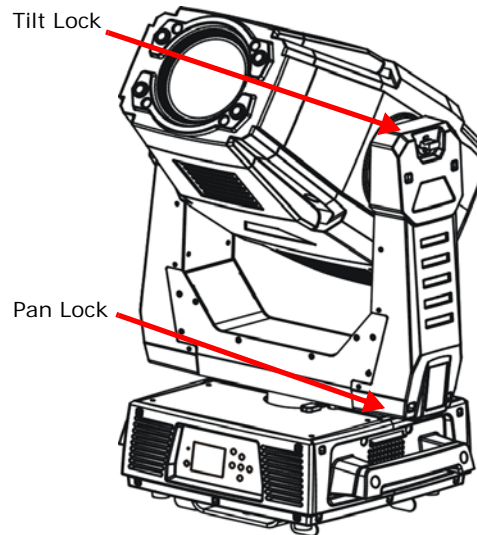

Installing a Power Cord Cap

The power cord for SolaSpot Pro CMY fixtures ships without a power cord cap. Use the information in this section to install the correct power cord cap for your location.

Because of the variety of power cord caps used worldwide, High End Systems, Inc. cannot make specific recommendations for the power cord cap. Contact a local authority for the type of power cord cap needed. When installing the power cord cap, note that the cores in the mains lead are colored according to the following code:

- green and yellow = earth
- white = neutral
- black = live

Installing a Line Cord Cap - U.K. Only

In the United Kingdom, core colours in the mains lead of this equipment may not correspond with the colored markings identifying the terminals in the fixture's plug. In that case, install a line cord cap in accordance with the following code:

- Connect the green and yellow core to the plug terminal marked with the letter "E," or by the earth symbol  or coloured green, or green and yellow.
- Connect the white core to the terminal marked with the letter "N" or coloured black.
- Connect the black core to the terminal marked with the letter "L" or coloured red.



WARNING:
Class 1 equipment - This equipment must be earthed.

Vatic Fitter Heads Information - Danmark

Advarsel: Beskyttelse mod elektrisk chock.

Vigtigt!

Lederne med gul/groen isolation maa kun tilsluttes en klemme maerket

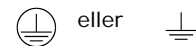

Mounting the Fixture

You can mount your SolaSpot Pro CMY fixture suspended from a support system (such as a truss) or freestanding on its base.



WARNING!
Equipment suitable for dry locations only. Do not expose this equipment to rain or moisture.



CAUTION!
SolaSpot Pro CMY fixtures must be installed and operated by trained personnel only.
Always use a secondary safety cable when mounting this fixture.



Do not mount within .5 meters (1.6 feet) of a flammable object.

Note: Due to the wide variety of possible lighting designs, High End Systems cannot make specific mounting recommendations. Consider the following procedures as suggested guidelines only.

Mounting the Fixture Upright



CAUTION!
Do not mount the fixture upright without the four rubber feet attached.

To mount the fixture upright, place the fixture on a sturdy, stable non-flammable surface that will support more than the 29.5 kg (65 lb) weight of the SolaSpot Pro CMY fixture. If the surface is above floor height, use safety cables to secure the fixture to the surface.

Truss Mounting

When mounting the fixture on a truss or another type of support:

- Verify the truss or support will handle the combined weight of all the devices on the truss. Each SolaSpot Pro CMY fixture weighs 29.5kg (65 lbs).
- Always mount a SolaSpot Pro CMY fixture using the mounting bracket assembly that shipped with your fixture and a safety cable attached to the fixture's base.



WARNING!
Before mounting, disconnect power to the fixture. If it has been operating, allow the fixture to cool for five minutes before handling.



CAUTION!
Only experienced lighting personnel should attempt to hang a lighting fixture to an appropriate theatrical truss.



WARNING!

In all cases a safety cable should also be fixed between the safety cable mounting holes located at the bottom of the fixture base housing and the truss. Failure to use a safety cable could result in injury or death. High End Systems supplies the proper safety cables and may be contacted for replacements if necessary. For more information go to: www.highend.com/trusshang

Use the following steps to mount a SolaSpot Pro CMY fixture on a standard truss:

1. Fix the clamp on the bracket by tightening the M12 screw on the bracket to the hole in the center of the bracket.
2. Insert the quick-lock fasteners of the first Omega holder into the respective holes on the bottom of the fixture. Tighten the quick-lock fasteners fully clockwise.
3. Install the second Omega holder.
4. Pull the safety-rope through the holes on the bottom of the base and over the trussing system or a safe fixation spot. Insert the end in the carabine and tighten the safety screw.

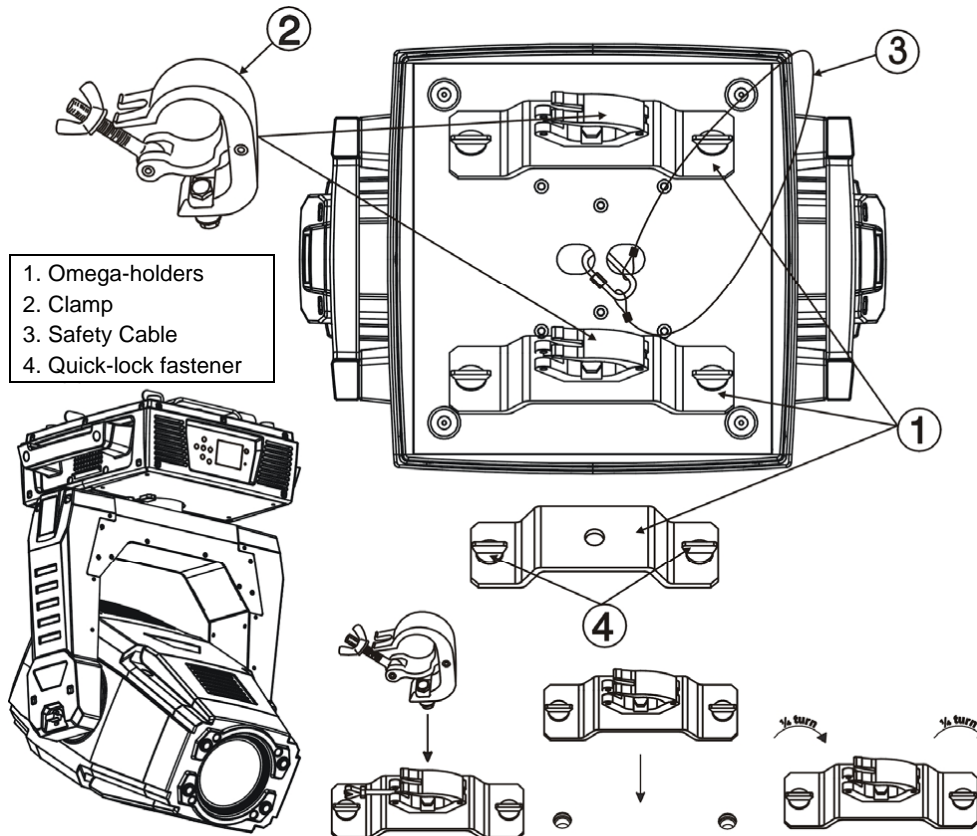

Linking SolaSpot Pro CMY Fixtures

The SolaSpot Pro CMY fixture operates on standard DMX512 link controlled by a DMX console. The number of fixtures on a link will be determined by the combined number of channels required by all the fixtures. A SolaSpot Pro CMY fixture requires a 35 channel footprint on a standard DMX512 link.

Attach the fixture to the link using data-grade cable and 5-pin or 3-pin XLR cable connectors.

Cable Connectors

The SolaSpot Pro CMY fixture accepts both 3-pin and 5-pin XLR cable connectors. Cabling must have a male XLR connector on one end of the cable and a female XLR connector on the other end.

Note: Pins four and five of a 5-pin cable connector are not used, but they allow a secondary data link to pass through the fixture.

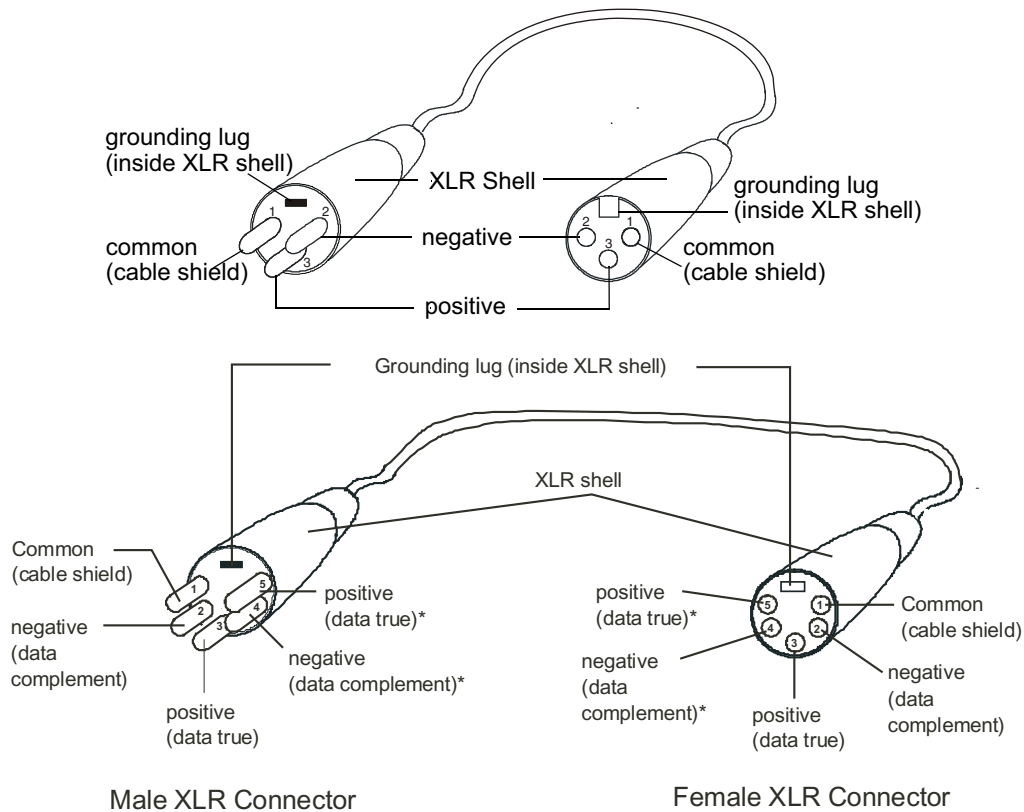

*This data line is not used by the fixture, but allows data to pass through the fixture.

Test each cable with a voltage/ohm meter (VOM) to verify correct polarity and to make sure that the negative and positive pins are not grounded or shorted to the shield or to each other.



CAUTION!

Do not connect anything to the ground lug on the XLR connectors. Do not connect or allow contact between the common (cable shield) and the fixture's chassis ground. Grounding the common could cause a ground loop and/or erratic behavior.

Connecting to the Link

To link one or more fixtures to a DMX controller:

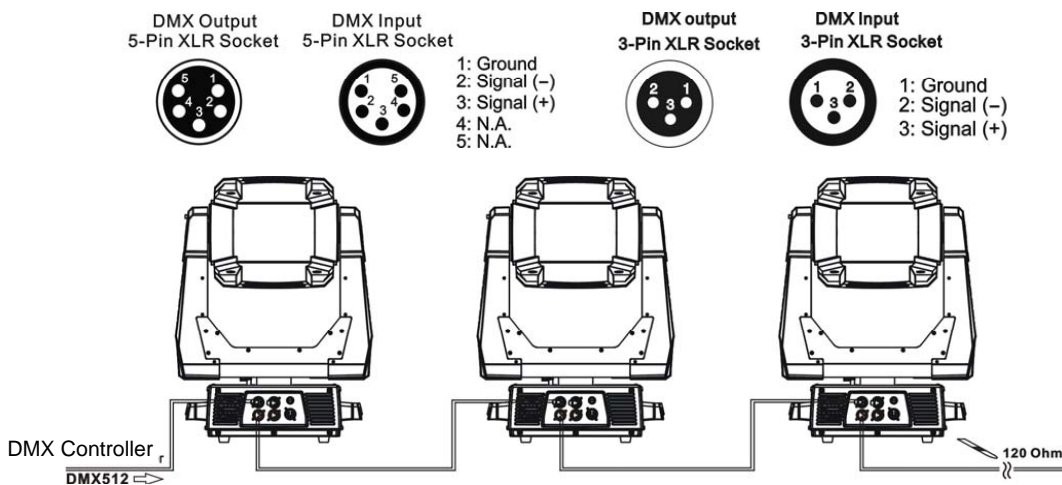

1. Connect the male XLR connector of a DMX Data cable to the controller's DMX Data Out connector.
2. Connect the Data cable's female XLR connector to the Data In connector of the first (or next) fixture on the DMX link.
3. Continue linking the remaining fixtures connecting a cable from the Data Out connector of each fixture to the Data In connector of the next fixture on the link.

For installations where the DMX cable has to run a long distance or is in an electrically noisy environment, a DMX terminator on the last fixture of the link prevents data reflection, which can corrupt the data communication on the link.

Terminate the link by installing a 120 ohm, 1/4 watt (minimum) terminator in the fixture's Data Out (female) cable connector in the last fixture on each DMX link.

To construct a terminator:

1. Disassemble a male 3-pin or 5-pin XLR connector.
2. Solder a 120 ohm resistor, minimum of 1/4 watt, between Pin 2 and Pin 3.
3. Reassemble the XLR connector.

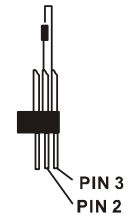
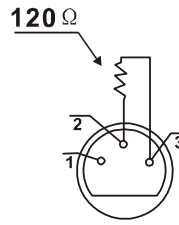

Configuring SolaSpot Pro CMY for DMX Control



Each SolaSpot Pro CMY fixture requires a block of 35 consecutive channels on a standard DMX512 link. Up to 16 units can be assigned to a single link. For more information on Start Channels, see *Determining DMX Start Channel Assignment* on page 23. Address your fixture by setting the first channel of the channel range you want to assign this fixture on the link.





Addressing is done for each unit using the fixture's menu system. You can access the menu system in battery mode to Address the fixture before you mount it or apply power.

Setting a Start Channel in Battery Mode

To address a SolaSpot Pro CMY fixture in battery mode:

1. Turn on the menu system by pressing and holding the Battery button for two seconds. The display will show the current Function and the Start Channel currently assigned to the fixture.
2. Press the  MODE/ESC button to enter the first level of the menu system. The display will show Address and Info as the first two options in the top menu level.

The red star * indicates the option you are on as you scroll through the levels using the  and  buttons.

The number at the bottom left of the display indicates the Menu Level you are on. Address is the first option on the first level.
3. Press the  Enter button to choose **Address**. The currently selected Start Channel is displayed in white.
4. Using the  and  buttons, scroll through other available values (displayed in red) to the desired start channel and press  to select. The newly selected value will now appear in white the next time you enter the menu.
5. The new address will not be stored until the  Enter button is pressed.

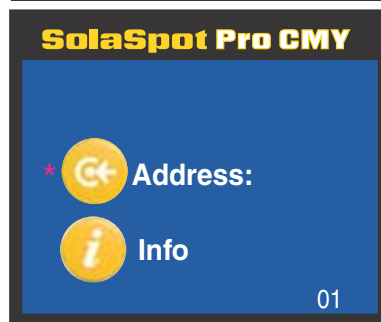

Note: For a detailed description of the entire menu system, see Chapter 3: Menu System on page 17.

Powering On the Fixture



WARNING:

This equipment is designed for connection to a branch circuit having a maximum overload protection of 20 A.



CAUTION:

Do not power on the fixture until *verifying* that the line cord cap is suitable for the power source in your location. For more information, see *Installing a Power Cord Cap* on page 8.

Disengage Pan and Tilt locks before operating the fixture. For more information, see *Pan and Tilt Locking* on page 7.

Do not unplug motor harnesses while unit is powered.

LED Radiation. Do not stare into beam. Class 2 LED product

To power on the SolaSpot Pro CMY fixture, simply connect it to a 100V-240V AC power source.

Once the SolaSpot Pro CMY fixture is connected to a power source, it automatically begins a homing procedure to verify that fixture components are functioning.

Shutting Down the Fixture

A DMX controller can shut down the fixture remotely with the Shutdown option in the Control Channel or you can simply disconnect from power. The SolaSpot Pro CMY fixture automatically shuts down in the event of DMX data loss longer than five minutes.

Chapter 3:

Menu System

This chapter shows you how to access and navigate the onboard Menu system and the options available for each menu with examples.



Menu System Overview

The front panel on SolaSpot Pro CMY fixtures has a full color LCD screen and navigation buttons to display and operate the onboard menu system. You can use the Menu system to perform the following functions at the fixture level:

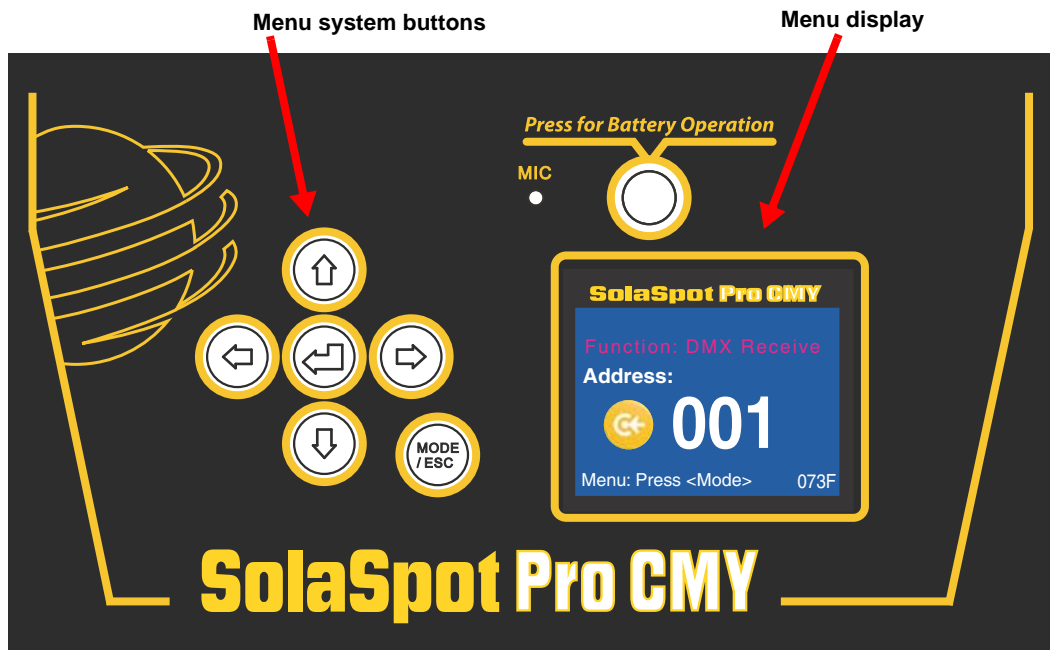
- Assign a DMX start channel
- Access and set fixture options
- View fixture status
- Create preset programs





Navigation Basics

1. Enter the Menu system by pressing the **Mode/Esc**  button for a few seconds until the menu appears.
2. The current option is displayed. Use the  and  buttons to scroll through menu options at the current level. The red star * indicates the current menu.

Note: *At the option or setting level of the menu, the currently selected option is displayed in white. Other options are displayed in red.*

3. Stop at the desired menu and press the **Enter**  button to select. If there is another level of menu choices repeat Steps 2 and 3.

Note: *The new option will not be stored unless the Enter button is pressed.*

4. Stop at the desired option and press the  button to select or press the  button to return to the previous menu level *without changing* the value of an option.

Note: *The currently selected option displays as white. Unselected options display in red.*

5. Continue pressing the  button to move back up levels until exiting the Menu system.

Note: *Some option changes do not take effect until you fully exit the menu system.*

Battery Operation

The SolaSpot Pro CMY fixture has an internal rechargeable battery that allows menu operation without power applied to the fixture.





To access the display menu in this mode, press the Battery button for two seconds.

Note: *Battery button will not respond if the fixture is receiving power.*

Exiting Battery Mode

The battery mode of the Menu will automatically switch off one minute after the last button press to conserve battery power.

To manually exit the Battery Mode:

1. Push the **Mode/Esc**  button once.
2. Use the  button to scroll to **Battery** and press the  button to select. **Exit Battery** will display in red (not currently selected).
3. Press the  button to select. The display will turn off.

SolaSpot Pro CMY Menu Map

Menu	Level 2	Level 3	Option/Setting	Description/Notes
🔑 Address	Set DMX: ###		1-478	Sets the first value of a unique 35 channel range on DMX link.
📘 Info	Time Info.	Current Time	####h	Power On running time in hours
		Ttl Life Hrs	####h	Fixture running time in hours
		Last Run Hrs	####h	Clears last Run Hours Time
		Timer PIN	XXX	Sets a Timer Password
		Clr Last Run		Resets last run time to 0
	Value Display	None		DMX Control
		All	XXX	Displays parameter's current DMX value
	Head Temp	XXX°C/°F		Displays head temperature in celsius and Fahrenheit
Software Ver	VerX.XXXX		Displays software version	
🔑 Set	Status	No DMX Mode	CloseShutter	Closes shutter when DMX is removed
			Hold	Holds the current Scene
			Auto Program	Reverts to Auto Program
			Music Ctrl	Reverts to Music Control
		Pan Reverse	On	Inverts Pan movement
			Off	Default
		Tilt Reverse	On	Inverts Tilt movement
			Off	Default
		Pan Degree	630/540	Manually sets Pan value in degrees
		Encoders	On	Encoders On
			Off	No encoder feedback
		Pan/Tilt Spd	Speed 1-4	Selects Movement Mode
	Mic Sens	0-99	Sets microphone sensitivity as a percentage	
	Hibernation	Off	No hibernation	
		01M-99M	Set time until hibernation in minutes	
		15M	Default Standby Mode	
	Service PIN	Service PIN	Password = ###	Service Password Default = 050
RDM PID		#####	Displays RDM PID	

Menu	Level 2	Level 3	Option/Setting	Description/Notes
☺ Set	Disp. Setting	Shutoff Time	02m-60m	Time until auto shutoff in minutes
		Flip Display	On	Rotates display 180°
			Off	Default display orientation
		Key Lock	On	Locks key
	Off		Allows key operation	
	Temp. C/F	Celsius	Selects Temperature Scale	
		Fahrenheit		
	Reset Default	On	Resets factory defaults	
Off		Maintains changes		
☹ Test	Home	All	Reset all motors	
		Others	Reset other motors	
		Gobos	Reset Gobos wheel	
		Colors	Reset color wheel	
		Pan & Tilt	Reset Pan/Tilt motors	
	Test Channel		Pan · · · Indigo Dim	Parameter test
	Manual Ctrl	Auto Program		Default
		Pan ... Indigo Dim	0-255	Manually sets a DMX value for any of the 35 individual parameters.
		Password		
	Calibration	Pan	0-255	Fine tunes homing position for individual motors
		Tilt	0-255	
		Dimmer	0-255	
		Color Wheel	0-255	
		Static Gobo	0-255	
		Rot Gobo	0-255	
		Shutter	0-255	
		Zoom	0-255	

Menu	Level 2	Level 3	Option/Setting	Description/Notes
🔽 Preset	Playback	DMX Control		Reverts to playback via console
		Set to Slave	Slave 1	Assigns slave setting
			Slave 2	
			Slave 3	
	Auto Program	Master	Assigns auto program mode	
		Alone		
	Music Control	Master	Assigns music control mode	
		Alone		
	Select Prog	Prog.Part 1	Program 1 ... Program 10	Selects program to be run in the Program part.
		Prog.Part 2	Program 1 ... Program 10	
		Prog.Part 3	Program 1 ... Program 10	
	Edit Program	Program 1 ... Program 10	Program Test	Runs the program as edited
			Step 01=SCxxx	Chooses a scene for each step in the selected program
			Step 64=SCxxx	
			End	Save and exit
	Edit Scenes	Edit Scene 001 ... Edit Scene 250	Pan · · · Indigo Dim	Allows you to set a DMX value for any of the 21 parameters. (see <i>DMX Programming</i> on page 39)
			Fade Time	Lets you set a fade time value from 000–255
			Scene Time	Lets you set a scene time from 00.2s–99.9s
Input by Out			Allows you to capture DMX values for all parameters into a scene	
Scenes Input	x x - x x		Automated scene recording	
🔋 Battery	Note: This menu only appears when you are in battery mode.		Exit Battery	Exits the battery mode and shuts off the display.

Menu System Options

The following sections describe and give examples for selecting and/or setting available fixture configuration options.

Address Menu

Address is the top level menu selection used to set the fixture's DMX start channel. You can address the fixture before applying power in the battery mode or in normal mode after you power up the fixture.



Note: *The last valid Start channel for a SolaSpot Pro CMY fixture is 478 (512–35+1).*

Setting a Start Channel





To address a SolaSpot Pro CMY fixture in battery mode:

1. Turn on the menu system by pressing and holding the Battery button for two seconds. The display will show the current Function and Start Channel assigned to the fixture.

2. Press the  MODE/ESC button to enter the first level of the menu system. The display will show Address and Info as the first two options in the top menu level.

The red star * indicates the current menu as you scroll through the level using the   buttons.

The number at the bottom left of the display indicates the Menu Level you are on. Address is the first option on the first level.

3. Press the  **Enter** button to choose **Address**. The currently selected Start Channel is displayed in white.
4. Use the   buttons to scroll to the desired start channel and press  to select.



Determining DMX Start Channel Assignment

There are 512 available channels on each DMX link divided among all the devices in a particular link. A fixture must have a unique Start channel number in order to respond independently to controller commands.

To determine each fixture's DMX start channel in a link, identify the channel range of every fixture on the link. Channel range is the number of consecutive channels a fixture requires. Each SolaSpot Pro CMY fixture requires a block of 35 consecutive channels on a 512-Channel DMX link. The Start channel is the first number of a fixture's channel range.

When setting the Start channel on a fixture, remember:

- A fixture's physical location on the link does not have to coincide with the order of channel range assignments in the link.
- The fixture's channel range must not overlap any other device's channel range on the link. When two devices on the same DMX link have overlapping channel ranges, one or both devices will be disabled or behave erratically. The single exception would be if two or more fixtures need to respond to controller commands in exactly the same way. In that case, those fixtures must be the same type (for example two SolaSpot Pro CMY fixtures) and must share the *entire* channel range.

The notes in the following table show the various considerations in determining valid Start Channels for fixtures on a 512 DMX link.





Fixture Rig Position	Fixture Type	DMX Channel Footprint	DMX Start Channel	Channel Range	Notes
First	SolaSpot LED	28 channels	C001	1-28	The Start channel is the first channel in a consecutive block of channels assigned to a fixture.
Third	SolaSpot Pro CMY	35 channels	C029	29-63	Fixture can be assigned the second block of DMX channels without being the second fixture on the rig.
Second	Technospot	37 channels	C079	79-116	Avoid overlapping channels with other fixtures
Fourth	Studio Spot	18 channels	C121	121-138	Every channel in the link does not need to be assigned.

Information Menu

The Information menu displays current fixture information such as internal temperature, total fixture hours, software version, and DMX values for each of the fixture's 35 parameters.

Fixture hours resets are executed in the Information Menu.







To enter the Information Menu:





1. Press the  MODE/ESC button to enter the first level of the menu system. The display will show **Address** and **Info** as the first two options in the top menu level.
2. Using the   buttons, scroll to **Info**.
3. Press the  button to select.

Time Info

The Time Info menu displays and resets certain time functions.

To view/reset time values or set passwords:

1. Navigate to and select **Info** menu as shown above. Time Info is the first option you will view.
2. Using the   buttons, scroll to **Time Info** and press the  button to select.
3. Using the   buttons, scroll to any of the following menu options and press the  button to select.







Current Time	Power On running time in hours
Ttl Life Hrs	Fixture running time in hours
Last Run Hrs	Fixture last times clear
Timer PIN	Use   buttons to set a Timer Password (Default PIN = 038)
Clr Last Run	OFF is the default value. Use   buttons to scroll to ON and select to reset to 0

4. Press the  button to confirm or  to return to previous menu level.

Values Display

This menu option lets you view the current DMX value for each of the fixture's 35 parameters.



To view DMX values by Parameter:

1. Navigate to and select the **Info** menu as shown on *page 24*.
2. Using the   buttons, scroll to **Values Display** and press the  button to select.
3. Using the   buttons, scroll to any of the DMX parameters in the SolaSpot Pro CMY protocol and press the  button to view its current DMX decimal value.

Head Temperature

The SolaSpot Pro CMY fixture contains temperature sensors that monitor the air temperature inside the housing near the display board.

To view temperature:



1. Navigate to and select the **Info** menu as shown on *page 24*.
2. Using the   buttons, scroll to **Head Temp** and press the  button to select.

The temperature will be displayed in degrees Celsius or Fahrenheit depending on which scale is currently selected in the **Set** menu, see *Temp C/F* on *page 28*.

Software Version

This Info menu option displays the current fixture software loaded on the unit. Software versions can vary even between units purchased at the same time.

To view fixture:

1. Navigate to and select the **Info** menu as shown on *page 24*.
2. Using the   buttons, scroll to **Software Ver** and press the  button to select.



Set Menu

The Set Parameters menu lets you configure your fixture's motion, display, and data source settings.

To enter the Set menu:











1. Press the  MODE/ESC button to enter the first level of the menu system. The display will show **Address** and **Info** as the first two options in the top menu level.

*The red star * indicates the current option.*

2. Using the   buttons, scroll to **Set**.
3. Press the  button to select.

Status Options

This menu lets you configure various fixture functions. To set a status option:

1. Navigate to and select the **Set** menu as shown above.
2. Using the   buttons, scroll to **Status** and press the  button to select.
3. Using the   buttons, scroll to one of the status options below and press the  button to select.
4. Using the   buttons, scroll to the desired setting and press  to select or  to return to the last menu level.

No DMX Mode

This option determines the fixture state after the DMX signal is removed. The Default setting is **Hold**. You can choose from the following options:

CloseShutter: Closes shutter when DMX is removed

Hold: Holds the current values for all parameters

Auto Program: Reverts to Auto Program Playback

Music Ctrl: Reverts to Music Control Playback

Pan Reverse

This menu option inverts the direction of the pan motor to coordinate movements between fixtures mounted opposite each other horizontally.

The default setting is **Off**. Select **On** to invert the fixture's Pan motion.

Tilt Reverse

This menu option inverts the direction of the tilt motor to coordinate movements between fixtures on a link facing each other vertically.

The default setting is **Off**. Select **On** to invert the fixture's Tilt motion.

Pan Degree

The standard pan range of a SolaSpot Pro CMY fixture is 0–540°. This option lets you expand the pan range to an upper limit of 630°.

To expand the pan range, scroll from the default option of **540** to **630** and press the  button to select.

Encoders

Encoders maintain the Pan and Tilt position of the fixture, but may need to be disabled to perform certain test and maintenance procedures. The default setting is **On**. To disable encoders, select the **Off** option.

Pan/Tilt Speed

This options adjusts the maximum movement speed of the pan and tilt parameters. The **Speed 1** option is the default normal movement speed. **Speed 2**, **Speed 3**, and **Speed 4** options are progressively slower maximum movement speeds.

Mic Sensitivity

You can adjust the input level for the internal microphone by setting this option from **0%** –**99%**. The Default value is **70%**.

Hibernation (Standby Mode)

This menu option determines how the fixture will react in the event of DMX data loss.









Turn Hibernation off to keep the shutter open until shutdown by selecting **Off**.

Scroll to any value from **01M** – **99M** to set the number of minutes after data loss before closing the shutter. The default setting is **15M**.

Service Setting

Two options for service setting allow you to set a **Service Password** or a **RDM PID** code.

To change the Service Password:









1. Navigate to and select the **Set** menu as shown on *page 26*.
2. Using the   buttons, scroll to **Status** and press the  button to select.
3. Using the   buttons, scroll to **Service PIN** and press the  button to select. The current password will be displayed. The default is **Password = 050**.
4. Using the   buttons, scroll to a 3-digit number and press the  button to select as the new service password.

Note: *A service password must be set before you can enter a six digit RDM PID number.*

Display Setting

This **Set** option lets you control how the display functions.

To select the Display Setting menu

1. Navigate to and select the **Set** menu as shown on *page 26*.
2. Using the   buttons, scroll to **Display Setting** and press the  button to select.
3. Using the   buttons, scroll to one of the following options below and press the  button to select.
4. Using the   buttons, scroll to one of the following options and press the  button to select.

Shutoff Time

This option lets you determines when the display automatically shuts off after the last button push. You can choose a delay from **02 – 60** minutes. The default delay setting is **02** minutes.

Flip Display

Use this option to rotate the display 180° when that orientation is easier to view. **Off** is the default setting. Select **On** to flip the display. Note that this option only takes affect once you exit the menu system by pressing the  MODE/ESC button.

Key Lock

This display setting lets you activate a key lock. **Off** is the default. Select **On** to activate the key lock and then press and hold the  MODE/ESC button for 2 seconds when you want to unlock the menu. When this function is activated, the keys will lock automatically after exiting the edit mode for 15 seconds.

Temp C/F



This options sets the temperature scale to **Celsius** or **Fahrenheit**. Celsius is the default setting.



Reset Default

This **Set** option lets you return all factory options. The default setting is **Off**. SolaSpot Pro CMY fixtures ships with the following factory default settings:

Pan Reverse = Disabled	Encoders = On	Flip display = Off
Tilt Reverse = Disabled	No DMX Mode = Hold	Keylock = Off
Pan Degree = 540	Temp C/F = Celsius	Microphone Sensitivity = 70%
Hibernation = 15M	Movement Speed = Speed 1	Shutoff Time = 2 minutes

To reset defaults:

1. Navigate to and select the **Set** menu as shown on *page 26*.
2. Using the   buttons, scroll to **Reset Defaults** and press the  button to select.

3. Using the   buttons, scroll to **On** and press the  button to select.



Test Options Menu

This menu lets you manually Home the fixture and change DMX values for parameters.

To Enter the **Test Options** Menu:

1. Press the  MODE/ESC button to enter the first level of the menu system. The display will show **Address** and **Info** as the first two options in the top menu level.

*The red star * indicates the current option.*

2. Using the   buttons, scroll to **Test**.
3. Press the  button to select.

Homing the Fixture

The SolaSpot Pro CMY fixture automatically homes whenever it is connected to power. The following options are available to let you manually home all the fixture motors or motors for specific functions:

All: Reset all motors





Others: Reset other motors

Shutter: Reset shutter and/or dimmer

Colors: Reset color wheel

Pan & Tilt: Reset Pan/Tilt motors









For example, to manually home the gobo wheel motors:

1. Navigate to and select the **Test** menu as shown above.
2. Using the  buttons, scroll to **Home** and press the  button to select.
3. Using the   buttons, scroll to **Gobos** and press the  button to select. The fixture automatically begins homing the motors for Gobo Wheel 1 and Gobo Wheel 2.

Manual Ctrl

This test option lets you manually set a DMX value for any of the SolaSpot Pro CMY fixture's 35 DMX channels. **Auto Program** is the default setting. Refer to *Chapter 5: DMX Programming* on page 39 for specific information on DMX value settings for each parameter.









For example, to change the static color wheel position to blue:

1. Navigate to and select the **Test** menu as shown above.
2. Using the   buttons, scroll to **Manual Ctrl** and press the  button to select.
3. Using the   buttons, scroll to **Color Wheel** and press the  button to select the fixed color wheel.
4. Using the   buttons, scroll to a value from **48–79** and press the  button to select the blue color position on the fixed color wheel.

Calibration

This **Test** menu option lets you fine tune the home position for each parameter.

To calibrate **Static Color Wheel** after homing:





1. Navigate to and select the **Test** menu as shown above.
2. Using the   buttons, scroll to **Calibration** and press the  button to select.
3. Using the   buttons, scroll to **Color Wheel** and press the  button to select.
4. Using the   buttons, adjust the Gobo Wheel 1 offset value and press the  button to store the calibration adjustment.

Preset Menu

The preset menu allows you to program scenes directly to the fixture. The options for designing and playing back presets are described in *Chapter 4: Preset Programming* on page 33.

Battery Menu

This menu is only available when you are currently operating in Battery Mode. Use the following steps to return to normal power mode:

1. Push the **Mode/Esc**  button.
2. Use the  button to scroll to **Battery** and press the  button to select. **Exit Battery** will display in red (not currently selected).
3. Press the  button to select. The display will turn off.

Chapter 4:

Preset Programming

SolaSpot Pro CMY fixtures can be programmed through the onboard menu system using Preset Programming. This section describes how to program your fixtures for stand-alone operation using the on-board memory in each fixture to create and store scenes.

Preset Programming Overview

Presets are built from combining scenes into programs and then assigning the programs to Program Partitions for playback by a fixture designated as the Master and, if desired, groups of slave fixtures assigned to a Program Partition. SolaSpot Pro CMY fixtures ship with factory programmed scenes and programs ready for you to use or edit.

Creating presets consists of performing the following steps:

- **Designating a fixture as the Master**
- **Selecting/Editing Scenes**
- **Sequencing Scenes into Programs**
- **Sequencing Programs into Program Partitions**
- **Configuring slave fixtures on the link to playback a Program Partition from the master**

Navigating to the Preset Menu

To enter the Preset Menu:

1. Press the  MODE/ESC button to enter the first level of the menu system. The display will show **Address** and **Info** as the first two options in the top menu level.

The red star * indicates the current menu.

2. Using the   buttons, scroll to **Preset**.
3. Press the  button to select.

Master and Slave

The following example shows the relationship between scenes, programs and partitions programmed on the Master and how slave groups are assigned.

- Groups of scenes are edited into Programs 1– 6 on the fixture designated as Master
- Program 2 is assigned to Part 1
- Program 4 is assigned to Part 2
- Program 6 is assigned to Part 3
- Fixtures assigned as Slave 1 playback Part 1
- Fixtures assigned as Slave 2 playback Part 2
- Fixtures assigned as Slave 3 playback Part 3

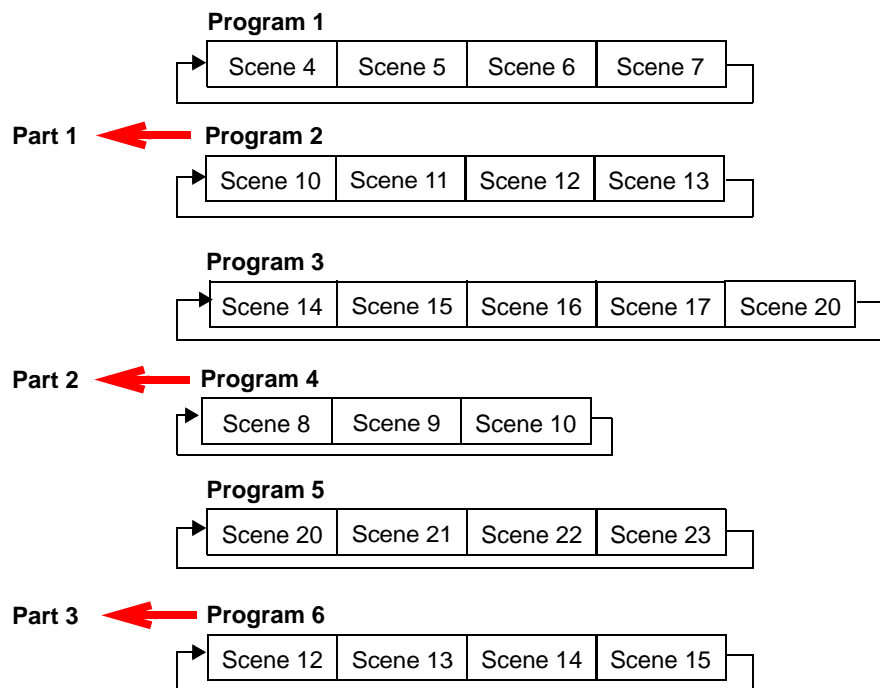

Preset Menu

Playback Settings









Preset programming requires one fixture to act as the Master. All other SolaSpot Pro CMY fixtures on the link can then be set as slaves to playback the Master presets. Slave fixtures receive all their preset parameter and timing information from the master fixture.

Playback settings designate a fixture as a master or a slave and also allow you to revert from Auto Programming to DMX control from a console or set a fixture in Master or standalone mode for audio control.

Automatic Program Run

This Playback option lets you designate a fixture to playback in Standalone mode or as a Master. **Alone** is the default setting.









To designate a fixture as a Master:

1. Navigate to and select the **Preset** menu as shown on *page 35*.
2. Use the   buttons to scroll to **Playback** menu and press  to select.
3. Use the   buttons to scroll to **Auto Program** menu and press  to select.
4. Use the   buttons to scroll to **Master** and press  to select. Your choice will be shown in the display.

Set to Slave

After a preset program is defined on a Master fixture, other SolaSpot Pro CMY fixtures on the same DMX link can be designated slaves to playback Program Part 1, 2 or 3 as defined on the Master fixture, see *Select Program* on page 38.

To designate a fixture as a Slave:

1. Navigate to and select the **Preset** menu as shown on *page 35*.
2. Use the   buttons to scroll to **Playback** menu and press  to select.
3. Use the   buttons to scroll to **Set To Slave** menu and press  to select.
4. Use the   buttons to scroll to **Slave1**, **Slave2**, or **Slave3** option and press  to select. Your choice will be shown in the display.

DMX Control

Selecting this option reverts the function from **Auto Program** (Preset Programming) to **DMX Receive** (console control). Selecting this option will take you back to the menu startup screen where **DMX Receive** will be displayed as the currently selected function.

Music Control

This Playback option lets you designate a fixture to playback scenes based on audio triggers detected by the internal microphone in stand alone or as a Master. **Alone** is the default setting.

Edit Scenes













A parameter is a fixture attribute that can be controlled to modify the light beam in terms of color, beam quality and pattern, intensity, or focus (position). DMX programming assigns a DMX value to each of the fixture's parameters. A *scene* is one combination of parameter settings.

SolaSpot Pro CMY fixtures provide 250 pre-programmed scenes you can use or edit to build a preset program. The first 64 scenes have factory created settings which can be edited as desired.

Edit Scene Parameters

The **Edit Scenes** option lets you select a DMX value for any of the 35 parameters in the SolaSpot Pro CMY DMX protocol.

To edit the DMX parameters in a scene:

1. Navigate to and select the **Preset** menu as shown on *page 35*.
2. Use the   buttons to scroll to the **Edit Scenes** option and press  to select.
3. Use the   buttons to scroll to the Scene number you wish to build on from 1-250 and press  to select.
4. Use the   buttons to scroll to the parameter you wish to edit (**Pan, Tilt, MSpeed, Color Wheel**, etc.) and press  to select.
5. Use the   buttons to scroll to a new DMX value for the parameter you have selected and press  to select.

This takes you back to parameter options. Continue through all parameters until your desired look is complete. See *Chapter 5: DMX Programming* on page 39 to find parameter values for the option you want to assign.

6. When you are finished selecting all parameter values for a particular Scene, press the  button to return to the **Preset** level menu.

Edit Scene Time











This Scene Edit option lets you set the scene time in seconds from **00.2s–99.9s**. The default value is **00.3s**. This value determines how long the scene will play before the next scene is triggered.

Set Fade Time

This Scene Edit option lets you set a fade time value from **000–255**. This value determines the crossfade time applied to parameters once the scene is triggered.

Set Input by Out













This Scene Edit option allows you to capture the parameter values for a scene from DMX input into the fixture. Once you create a look from a DMX console do the following:

1. Navigate to and select the **Preset** menu as shown on *page 35*.
2. Use the   buttons to scroll to the **Edit Scenes** option and press  to select.
3. Use the   buttons to scroll to the Scene number you wish to build on from 1-250 and press  to select.
4. Use the   button to scroll to the **Input by Out** and press  to select.
5. The scene will record the current parameter values being input via DMX.
6. When you are finished capturing DMX into a scene, press  to return to the main menu.

Edit Program

This preset menu option lets you select from 10 factory set programs to edit. You can set up to 64 **Scenes** in a sequence of **Steps** for each program. You can also test the program at any time by selecting **Program Test** to playback the program as it is currently defined.

To edit a program:























1. Navigate to and select the **Preset** menu as shown on *page 35*.
2. Use the   buttons to scroll to **Edit Prog.** menu and press  to select.
3. Use the   buttons to scroll to a program from **Program 1–Program 10** and press  to select.
4. Use the   buttons to scroll to the Step in the program you want to edit from **Step 1** to **Step 64** and press  to select. The display will show which scene is currently assigned to that step.
5. Use the   buttons to scroll to the scene you want to assign to the step and press  to select.
6. When you have assigned all the steps you want, select End and press  to save the program.

Select Program

This preset option lets you assign a Preset Program to one of three Program Partitions. A fixture assigned as a Slave can playback any Program Partition defined by the Master fixture.







Note: *The Master fixture can only playback Program Partition 1*

To assign a program to each Program Partition:

1. Navigate to and select the **Preset** menu as shown on *page 35*.
2. Use the   buttons to scroll to **Select Prog** menu and press  to select. Each Program Part, has 10 preset programs.
3. Use the   buttons to scroll to **Prog. Part 1** and press  to select.
4. Use the   buttons to scroll to a program from **Program 1–Program 10** and press  to select the program you want to include in the Program Part.
5. Use the   buttons to scroll to **Prog. Part 2** and press  to select.
6. Use the   buttons to scroll to a program from **Program 1–Program 10** and press  to select the program you want to include in the Program Part.
7. Use the   buttons to scroll to **Prog. Part 3** and press  to select.
8. Use the   buttons to scroll to a program from **Program 1–Program 10** and press  to select the program you want to include in the Program Part.
9. Press the  button to return to the main menu.

Scenes Input

This function allows you to capture multiple scenes from DMX values input to the fixture. You first define the number of scenes to capture and then each time a DMX value changes, a different scene will be captured.

1. Navigate to and select the **Preset** menu as shown on *page 49*.
2. Use the   buttons to scroll to the **Scenes Input** option and press  to select.
3. Use the   buttons to set the starting scene number.
4. Use the   buttons to set the ending scene number. With each change of any DMX value, the capturing scene will advance to the next one in the range.
5. When all scenes have been recorded, the scenes input menu will automatically exit.

Note: *During Scenes Input recording, the SolaSpot Pro CMY does not playback the DMX input, it only captures it. You must edit or playback the scenes after recording to see the results. It is best to prepare the scenes on a DMX controller with a zero crossfade for all parameters between each step. Remember any change of a DMX value will advance to the next scene to capture.*

Chapter 5:

DMX Programming

SolaSpot Pro CMY fixtures can be programmed to provide a hard edge beam with full static color, multiple gobo patterns and effects. This chapter gives a brief overview of DMX programming and describes SolaSpot Pro CMY DMX parameters.

DMX Programming Overview

A parameter is a fixture attribute that can be controlled to modify the light beam in terms of color, beam quality and pattern, intensity, or focus (position). DMX programming assigns a DMX value to each of the fixture's parameters. A *scene* is one combination of parameter settings. Scenes are the building blocks for show creation.

Full Speed versus MSpeed Control

Some parameters can be set to operate at full speed or MSpeed (motor speed). Full speed operations are completed in the shortest length of time after the motor starts moving. With MSpeed control, change occurs smoothly over the entire MSpeed time value selected. For example, if you select an MSpeed time of 30 seconds, the motor will gradually change position until it reaches its new destination at the end of 30 seconds.

SolaSpot Pro CMY fixtures allow optional MSpeed control for pan and tilt movement parameters.

16-bit Functionality

Several parameters use two channels to provide 16-bit control for very fine adjustment capabilities.

DMX Programming Options

Using a DMX controller, you can program an unlimited number of looks and retain direct control over the SolaSpot Pro CMY fixture at all times.

SolaSpot Pro CMY fixtures also allow Preset programming through the fixture menu system, see *Chapter 5: Preset Programming* on page 47.

Programming with a DMX Console

Hog[®] 4, Road Hog[®] 4, Full Boar 4, and Hedge Hog lighting consoles; and Hog[®] 4PC software are available from High End Systems to control SolaSpot Pro CMY fixtures (see *Related Products and Accessories* on page 5). For information on whether your DMX controller supports SolaSpot Pro CMY fixtures, contact the controller's vendor. For information on operating your fixture with a

controller (or control device such as DMX control software), consult the documentation provided with the controller.

SolaSpot Pro CMY DMX Protocol

The SolaSpot Pro CMY fixture uses 35 channels of a standard DMX512 link to control motion, wheel functions, focus, zoom, iris, shutter and lamp function.

Channel	Function
1	Pan
2	
3	Tilt
4	
5	Mix Color Function
6	Cyan
7	Magenta
8	Yellow
9	CTO
10	Static Color Function
11	Static Color Position
12	Rotating Gobo Function
13	Rotating Gobo Position
14	Rotating Gobo Rotate Function
15	Rotating Gobo Rotate
16	
17	Fixed Gobo Wheel Function
18	Fixed Gobo Wheel Position

Channel	Function
19	Prism Function
20	Prism Rotate
21	
22	Frost
23	Focus
24	
25	Zoom
26	
27	Iris
28	Shutter/Lamp Function
29	Shutter
30	Dim
31	
32	MSpeed
33	Control
34	Indigo Highlighter Function
35	Indigo Highlighter Dim

These parameters are described in the following sections.

Note: *All DMX values indicated in the detailed parameter descriptions are in decimal units.*

Pan and Tilt Parameters

The SolaSpot Pro CMY fixture has a 540° pan range and a 265° tilt range. Two DMX channels provide 16-bit adjustment to a fraction of a degree for pan and tilt position.

An MSpeed function is available for Pan and Tilt parameters when the MSpeed parameter. For information on implementing MSpeed, see *MSpeed (Motor Speed)* on page 52.

Note: *Optical encoders for pan and tilt instantly correct the fixture's position if the fixture is jarred from its programmed position. If a physical obstruction prevents the fixture from correcting its position, the fixture "times out" to prevent wear on the motors. If the fixture has timed out, remove the obstruction and home the fixture to return it to normal operation.*

Color Parameters

CMY color mixing is achieved using three sets of color flags (Cyan, Magenta, and Yellow). A fixed color wheel provides an additional eight factory selected dichroic color filters.

Color Mix Function

This parameter determines how the Cyan, Magenta, and Yellow color flags move.

DMX Value	Color Mix Function	Description
0-47	Pure Mix	Allows color flag movement from open (white) to saturated color.
48-63	Cycle	Uses the color-mixing Cyan, Magenta, and Yellow color flags to cycle colors from red to green to blue at variable speeds (rate set by Cyan DMX channel).
64-79	Random	Performs a pseudo-random color chase of factory-selected colors using the Cyan, Magenta, and Yellow color flags at variable speeds (rate set by Cyan DMX channel).

Cyan, Magenta, and Yellow

These three parameters determine the **Cyan**, **Magenta**, and **Yellow** color flag position and movement speed depending on the **Color Mix Function** parameter value you select.

Color Mix Function Setting	Cyan, Magenta, and Yellow Parameter Option	
	DMX Value	Description
Pure Mix	0-255	Positions color flags from full saturation to open (white)
Cycle and Random	0-255	The Cyan color flag sets the speed at which all three (Cyan, Magenta, and Yellow) flags move to the next cycle or random color from slowest to fastest.

Static Color Function

SolaSpot Pro CMY fixtures have a fixed color wheel with eight color positions plus Open.

The **Static Color Function** parameter determines how the fixed color wheel moves.

Static Color Function	DMX Value	Description
Indexed	0-15	Allows the color wheel to take the quickest path and snap to the chosen whole or half color
Forward Spin	16-31	Spins the fixed color wheel forward at variable speeds
Reverse Spin	32-47	Spins the fixed color wheel in reverse at variable speeds
Continuous	48-63	Moves to any point on the color wheel to allow a smaller “step” between color wheel positions
Fast Scan	64-79	Oscillates the fixed color wheel at a factory-determined range and speed
Random	80-95	Selects random whole color positions at variable speeds

Static Color Position

Static Color Position parameter controls fixed color wheel positioning. The **Static Color Function** setting you choose determines how the individual color mixing wheels can move.

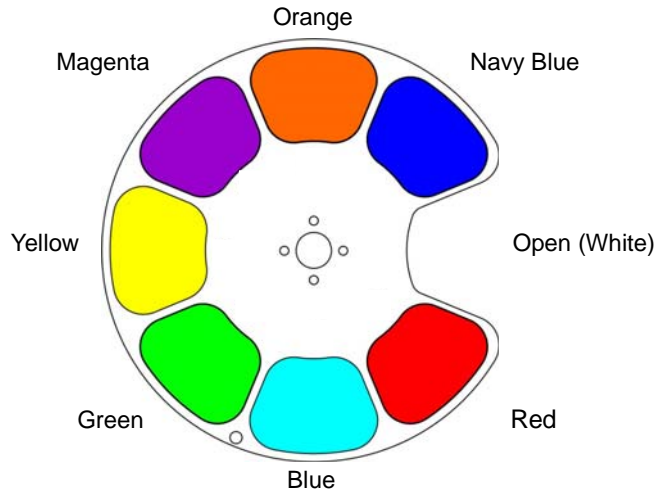

Color Function Setting	Static Color Position Options		
	Color	DMX Value	Description
Indexed or Scan Modes	White (Open)	0-15	Position the wheel at the center of a color wedge or halfway between two adjacent colors from Open (white) to Open
	Red	16-30	
	Red/Blue	31-45	
	Blue	46-60	
	Blue/Green	61-75	
	Green	76-105	
	Green/Yellow	106-120	
	Yellow	121-135	
	Yellow/Magenta	136-150	
	Magenta	151-165	
	Magenta/Orange	166-180	
	Orange	181-195	
	Orange/Cyan	196-210	
	Cyan	211-225	
	Cyan/White	226-240	
White (Open)	241-255		
Spin or Random Modes	All Positions	0	Stop wheel motion
		1-255	Adjusts the wheel motion from slowest to fastest
Continuous Mode	All Positions	0-255	Position the wheel at any point from 0–360°

Gobo Wheel Parameters

A SolaSpot Pro CMY fixture has two Gobo wheels each with seven rotating lithopatterns™ plus open. Both Gobo wheels use **Gobo Function** and **Gobo Position** parameters to control the positioning and rotation of the Static Gobo wheel. The Rotating Gobo Wheel uses **Gobo Rotate Function** and **Gobo Rotate** parameters to control individual aperture position and rotation on the wheel.

Static Gobo Wheel Parameters

Static Gobo Function

This parameter provides options for how you control the wheel spin and gobo selection on the Static Gobo Wheel.

Static Gobo Function	Description
Indexed	Takes the quickest path and snaps to the chosen gobo position on the wheel.
Forward Spin	Spins the wheel forward through the gobo positions at variable speeds.
Reverse Spin	Spins the wheel in reverse through the gobo positions at variable speeds.
Scan	Performs a scan of one gobo position from each side
Random	Selects random gobo positions at variable speeds.

Note: *You can access the transition patterns using the continuous Gobo function.*

Static Gobo Position

This parameter lets you select from seven anamorphic patterns plus open on the Static Gobo Wheel.

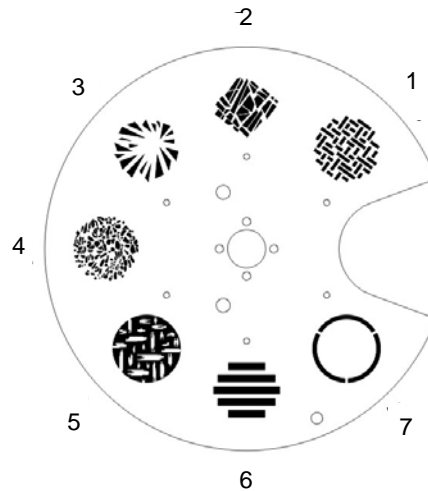

Color Function Setting	Static Color Position Options		
	DMX Value	Pattern	Description
Indexed or Scan Mode	0-15	Open	Position the wheel at the center of a color wedge or halfway between two adjacent colors from Open (white) to Open
	16-47	Tunnel	
	48-79	Bars	
	80-111	Strokes	
	12-143	Foliage	
	144-175	Burst	
	176-207	Fracture	
	208-239	Crosshatch	
	240-255	Open	
Spin or Random Mode	0	All Positions	Stop wheel motion
	1-255		Adjusts the wheel motion from slowest to fastest

Rotating Gobo Wheel Parameters

Rotating Gobo Function

The **Rotating Gobo Function** parameter determines how the Rotating Gobo wheel moves.

DMX Value	Gobo Wheel Function	Description
0-15	Indexed	Moves by the quickest path and snaps to the chosen aperture.
16-31	Forward Wheel Spin	Spins the gobo wheel forward at variable speeds.
32-47	Reverse Wheel Spin	Spins the gobo wheel in reverse at variable speeds.
48-63	Scan	Oscillates the gobo wheel at a factory-determined range and speed.
64-79	Random	Selects random aperture positions at variable speeds.

Rotating Gobo Position

A **Rotating Gobo Position** parameter positions the wheel in the optical path at the center of the aperture to perform the function selected by the **Rotating Gobo Function** parameter.

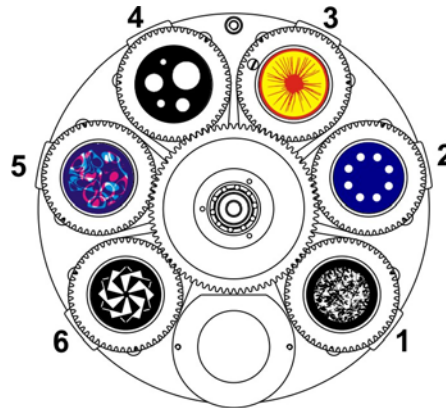

Rotating Gobo Wheel Function Setting	Static Color Position Options		
	DMX Value	Gobo Position	Description
Indexed or Scan Mode	0-31	Open	Positions the wheel at the center of a gobo position pattern
	32-63	Dense Foliage	
	64-95	Gatlin	
	96-127	PsySpin	
	128-159	Bubbles	
	160-191	Lumiol	
	192-223	Paper Stack	
	224-255	Open	
Spin or Random Mode	0	All Positions	Stops wheel motion
	1-255		Adjusts the wheel motion from slowest to fastest

Rotating Gobo Rotate Function

Gobo rotate refers to the motion of the individual aperture wheels on the Rotating Gobo Wheel. The **Rotating Gobo Function** parameter determines modes for gobo rotation.

DMX Value	Rotating Gobo Function	Rotating Gobo Rotate Function Description
0-15	Indexed	Rotates the specified indexed aperture to any position
16-31	Forward Rotate	Rotates the aperture forward
32-47	Reverse Rotate	Reverses the aperture rotation

Rotating Gobo Rotate

Two channels for the Gobo Wheel provide 16-bit control for smooth and precise Gobo Rotation. **Rotate Coarse** and **Rotate Fine** parameters determine an apertures' rotation position and speed.

Rotating Gobo Rotate Function Setting	Rotating Gobo Rotate Parameter Options	
	DMX Value	Description
Indexed	0-255	Rotate the specified indexed aperture to any position
Rotate Mode	0-3	Stop rotation
	4-255	Set rotation speed from slowest to fastest

Prism Parameters

The SolaSpot Pro CMY fixture has a separate 4-facet prism that can be placed and rotated in the optical path and used along with gobo patterns and color mixing.

Prism Function

The Prism Rotate Function parameter determines how the prism wheel moves.

Effect Rotate Function	DMX Value	Description
Disengage	0-15	Removes prism from the optical path
Continuous	15-31	Sets prism to a specific point
Forward Spin	32-47	Spins the prism effect forward
Reverse Spin	48-63	Reverses the spin of the prism wheel

Prism Rotate

The **Prism Rotate** parameters use two channels for 16-bit control of the prism position and speed, depending on the **Prism Rotate Function** option selected.

Effect Rotate Function	Effect Rotate Parameter Option	
	DMX Value	Description
Continuous	0-255	Rotates the prism to a position from 0°-360°
Rotate	0	Stop rotation
	1-255	Set rotation speed from slowest to fastest

Frost Parameter

The **Frost** parameter focus lets you vary the beam edge from soft to hard or execute a strobing effect.

Frost Function	DMX Value	Description
Open	0	Hard edged beam
Variable Edge	1-127	Varies the edge from hard to soft edge
Soft Edge	128-135	Soft edge
Periodic Strobe	32-47	Soft Edge
Random Strobe	48-63	Reverses the spin of the prism wheel
Open	0-15	Hard edged beam with the prism removed from the optical path

Focus Parameters

Two channels determine the focus function providing 16-bit control for smooth and precise control. The **Focus Course** and **Focus Fine** parameters focus from in at a DMX value of 0 to out at a DMX value of 255.

Zoom Parameters

The SolaSpot Pro CMY fixture has zoom range from 12° to 40°. The **Zoom Coarse** and **Zoom Fine** parameters provide 16-bit continuous control for smooth and precision zoom function from in at a DMX value of 0 to out at a DMX value of 255.

Iris Parameter

The SolaSpot Pro CMY iris has a variable circular opening that controls the beam diameter in a similar fashion as a camera's iris controls the amount of light entering the camera. **Iris** is a continuous parameter that adjusts the iris from closed at a DMX of 0 to open at a DMX value of 255.

Shutter Parameters

Shutter Function

This parameter control normal shutter and strobing features.

Shutter Options	DMX Value	Description
Normal Shutter Functions	0-31	Opens and closes shutter flags in the optical path
Random Random Strobe	32-63	Strobes beam using the shutter flags at random intervals
Synchronous Random Strobe	64-95	Synchronizes random strobing for all SolaSpot Pro CMY fixtures using the same DMX controller
Normal Shutter Functions	96-255	Opens and closes shutter flags in the optical path

Shutter

The **Shutter** parameter determines sets the strobing rate.

DMX Value	Shutter Parameter Options
0-23	Close shutter
24-229	Set strobe rate from slowest to fastest
230-255	Open shutter

Dim

SolaSpot Pro CMY fixtures provide 16-bit brightness control utilizing the **Dim Coarse** and **Dim Fine** parameter without changing the color temperature or the beam shape. The dim values range from Off at a DMX value = 0 to fully on when the DMX value = 255).

MSpeed (Motor Speed)

MSpeed is the time required for a motor to complete movement when changing from one position to another. In SolaSpot Pro CMY fixtures, MSpeed provides a means for Pan and Tilt motors to reach their target position at the same time, even though each motor may have different distances to travel. MSpeed movement is extremely smooth because the fixture controls movements independent of DMX refresh rates.

MSpeed times vary from 0.15 seconds to 252.7 seconds. However, when MSpeed is applied to a parameter, the delay value (length of time allowed for the entire scene) needs to be longer than the MSpeed value to allow the motors to complete their movement before the end of the scene. An MSpeed value that is longer than the delay value could produce an undesirable result; for example, no light output during the scene. For a listing of exact MSpeed times, see *Chapter A: MSpeed Conversion Table* on page 57.

Control

The **Control** parameter allows remote control of Display, Homing, Lamp and Shutdown.

Note: To access all control settings, first select a control channel value, then set the Shutter channel to DMX = 0.

Control Setting	DMX Value	Description
Safe	0-9	Disables all Control settings for normal operation
Pan and Tilt MSpeed Off	10-19	
Display Off	20-28	Turns display off
Display On	29-48	Turns display on
Home All	49-68	Remotely homes all the fixture components
Shutdown	69-130	Remotely shuts down the fixture. When a fixture is shut down, the LEDs are off and power to the motors is disabled. If a fixture is in shutdown mode, the fixture must be homed to bring it back into operation.
Audio Sync	131-160	Synchronizes audio playback
Internal Program 1	161-171	Runs an 8-Scene factory programming Macro that can be edited by the user.
Internal Program 2	172-182	
Internal Program 3	183-193	
Internal Program 4	194-204	
Internal Program 5	205-215	
Internal Program 6	216-226	
Internal Program 7	227-237	

Indigo Highlighter

Indigo Highlighter system consists four 1-watt indigo LEDs that provide additional light output. Two parameters define the Indigo Highlighter operation.

Indigo Highlighter Function

You can choose to have the Indigo Highlighter system function independently from the fixture's dimming or track it.

Indigo Highlighter Function	DMX Value	Description
Continuous	0-15	Tracks the fixture dimming with continuous output
Periodic Strobe	16-41	Tracks the fixture dimming with periodic strobing from slowest to fastest
Continuous	128-143	Continuous output independent from fixture dimming
Periodic Strobe	144-169	Strobing output independent from fixture dimming from slowest to fastest

Indigo Highlighter Dim

This parameter adjusts the Indigo Highlighter LEDs from **Off** at a DMX value of 0 to fully **On** at a DMX value of 255.

Chapter 6:

General Maintenance and Troubleshooting

This chapter outlines safety and maintenance procedures as well as troubleshooting error messages.

Safety Considerations



CAUTION: The information in this chapter is intended to assist qualified personnel *only*.



WARNING: Disconnect power before servicing. Replace fuses with the specified type and rating *only*.

Maintenance

There are no serviceable parts inside the device except for the lamp. The following points have to be considered when inspecting the fixture for maintenance:

- All screws for installing the devices or parts of the device have to be tightly connected and must not be corroded.
- Mechanically moved parts must not show any traces of wearing and must not rotate with unbalances.
- The electric power supply cables must not show any damage, material fatigue or sediments.

Replacing Rotating Gobos

The SolaSpot Pro CMY fixture is designed with removable rotating gobo apertures. This allows a gobo to be changed easily without removing the wheel from the unit.

Note: *It is imperative that gobo holders are removed and replaced one at a time. One of the holders has a homing magnet and must be installed into the correct location. Failing to do so will result in gobo index homing errors.*

To change a rotating gobo:

1. Remove one of the bezel covers and set the tilt lock to stabilize the unit in a convenient position.
2. Rotate the wheel to the desired gobo.
3. Push up on the exposed tab of the litho holder.
4. Grasp the litho holder and remove it from the wheel.



5. Lift the spring and remove it with the aperture ring and the gobo.
6. Position the gobo into the aperture, so that when it is placed back in the wheel, the coated side will be away from the lamp.



- Note** *Install the litho according to the manufactures specifications. High End Systems lithos are installed with the coated side facing away from the light source.*

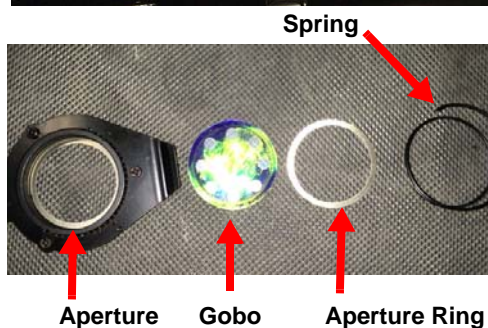

7. Replace the ring and spring.
8. Install the gobo holder into the wheel by lining up the inner tab of the gobo holder to the tensioner on the wheel.
9. Push the gobo holder into the wheel and insure the holder sits flat on the wheel.
10. After replacing the gobo, clean it by using a soft, lint-free cotton cloth and a mild glass cleaning solution (containing no ammonia).

Cleaning the Fixture

- Clean the inside and outside lens each week to avoid the weakness of the lights due to accumulation of dust.
- Clean the fan each week.
- To ensure smooth gobo rotation, lubricate the wheel every three months.



Warnings:To avoid electrical shock, disconnect power before servicing.

Equipment surfaces may reach temperatures up to 130° C (266° F). Allow the fixture to cool before handling.

To clean the internal glass components:

1. Disconnect power to the fixture. If the fixture has been operating, allow the fixture to cool before handling.
2. Clean the dichroics, lithopatterns and effects, color wheels, and lens using a mild glass cleaner (containing no ammonia) and a soft, lint-free cotton cloth.

Troubleshooting Error Messages

When you turn on the fixture, it will make a reset at first. The display may show "Err channel is XX" while there are problems with one or more channels. "XX" stands for channel 1, 2, 3, 4, 5, 6 who has the testing sensor for positioning. For example, when the display shows "Err channel is Color wheel", it means there is some error in channel 11. If there are some errors on channel 1, channel 3, channel 8 at the same time, you may see the error message "Err channel is Pan movement", "Err channel is Tilt movement", "Err channel is Color wheel" flash repeated for 2 times, and then the fixture will generate a second reset. If the fixture remain error message after performing reset more than 2 times, only the channels which have errors can not work properly, others can work as usual. Please contact with dealer or manufacturer for service, self repair is not allowed.

PAN- movement Er

(PAN-yoke movement error) This message will appear after the reset of the fixture if the yoke's magnetic-indexing circuit malfunction (sensor failed or magnet missing) or the stepping-motor is defective (or its driving IC on the main PCB). The PAN- movement is not located in the default position after the reset.

TILT- movement Er

(TILT-head movement error) This message will appear after the reset of the fixture if the head's magnetic-indexing circuit malfunctions (sensor failed or magnet missing) or the stepping-motor is defective (or its driving IC on the main PCB). The TILT- movement is not located in the default position after the reset.

Gobo Wheel 1 Er

(Gobo Wheel 1- error) This message will appear after the reset of the fixture if the magnetic-indexing circuit malfunction (sensor failed or magnet missing) or the stepping-motor is defective (or its driving IC on the main PCB). The Gobo Wheel 1 is not located in the default position after the reset.

Gobo Wheel 2 Er

(Gobo Wheel 2- error) This message will appear after the reset of the fixture if the magnetic-indexing circuit malfunction (sensor failed or magnet missing) or the stepping-motor is defective (or its driving IC on the main PCB). The Gobo Wheel 2 is not located in the default position after the reset.

Color wheel Er

(Color wheel- error) This message will appear after the reset of the fixture if the magnetic-indexing circuit malfunction (sensor failed or magnet missing) or the stepping-motor is defective (or its driving IC on the main PCB). The color wheel is not located in the default position after the reset.

Zoom Er

(Zoom-error) This message will appear after the reset of the fixture if the magnetic-indexing circuit malfunction (sensor failed or magnet missing) or the stepping-motor is defective (or its driving IC on the main PCB). The Zoom is not located in the default position after the reset.

Focus Er

(Focus-error) This message will appear after the reset of the fixture if the magnetic-indexing circuit malfunction (sensor failed or magnet missing) or the stepping-motor is defective (or its driving IC on the main PCB). The Focus is not located in the default position after the reset.

Appendix A:

MSpeed Conversion Table

The following table lists the MSpeed (motor) movement times and their corresponding DMX controller values. If you have a numeric-type controller, use the Value Decimal (dec.) column. If you have a fader-type controller, use the Value Percentage (%) column. If your controller allows you to program hex values, use the Value (hex) column.

Time (sec.)	Value (dec.)	Value (%)	Value (hex)	Time (sec.)	Value (dec.)	Value (%)	Value (hex)	Time (sec.)	Value (dec.)	Value (%)	Value (hex)
0.15	255	100	FF	5.94	217	85	D9	23.30	179	70	B3
0.15	254	100	FE	6.25	216	85	D8	23.92	178	70	B2
0.17	253	99	FD	6.56	215	84	D7	24.54	177	69	B1
0.19	252	99	FC	6.89	214	84	D6	25.17	176	69	B0
0.21	251	98	FB	7.22	213	84	D5	25.80	175	69	AF
0.25	250	98	FA	7.56	212	83	D4	26.45	174	68	AE
0.29	249	98	F9	7.91	211	83	D3	27.10	173	68	AD
0.35	248	97	F8	8.27	210	82	D2	27.76	172	67	AC
0.41	247	97	F7	8.63	209	82	D1	28.43	171	67	AB
0.47	246	96	F6	9.00	208	82	D0	29.11	170	67	AA
0.55	245	96	F5	9.39	207	81	CF	29.80	169	66	A9
0.63	244	96	F4	9.77	206	81	CE	30.49	168	66	A8
0.73	243	95	F3	10.17	205	80	CD	31.19	167	65	A7
0.83	242	95	F2	10.58	204	80	CC	31.90	166	65	A6
0.94	241	95	F1	10.99	203	80	CB	32.62	165	65	A5
1.05	240	94	F0	11.41	202	79	CA	33.34	164	64	A4
1.18	239	94	EF	11.84	201	79	C9	34.08	163	64	A3
1.31	238	93	EE	12.28	200	78	C8	34.82	162	64	A2
1.45	237	93	ED	12.72	199	78	C7	35.57	161	63	A1
1.60	236	93	EC	13.17	198	78	C6	36.33	160	63	A0
1.75	235	92	EB	13.63	197	77	C5	37.09	159	62	9F
1.92	234	92	EA	14.10	196	77	C4	37.87	158	62	9E
2.09	233	91	E9	14.58	195	76	C3	38.65	157	62	9D
2.27	232	91	E8	15.07	194	76	C2	39.44	156	61	9C
2.46	231	91	E7	15.56	193	76	C1	39.44v	156	61	9C
2.66	230	90	E6	16.06	192	75	C0	40.23	155	61	9B
2.86	229	90	E5	16.57	191	75	BF	41.04	154	60	9A
3.07	228	89	E4	17.09	190	75	BE	41.85	153	60	99
3.29	227	89	E3	17.61	189	74	BD	42.68	152	60	98
3.52	226	89	E2	18.14	188	74	BC	43.50	151	59	97
3.76	225	88	E1	18.68	187	73	BB	44.34	150	59	96
4.00	224	88	E0	19.23	186	73	BA	45.19	149	58	95
4.25	223	87	DF	19.79	185	73	B9	46.04	148	58	94
4.52	222	87	DE	20.36	184	72	B8	46.90	147	58	93
4.78	221	87	DD	20.93	183	72	B7	47.77	146	57	92
5.06	220	86	DC	21.51	182	71	B6	48.65	145	57	91
5.34	219	86	DB	22.10	181	71	B5	49.54	144	56	90
5.64	218	85	DA	22.70	180	71	B4	50.43	143	56	8F

Appendix A
MSpeed Conversion Table

Time (sec.)	Value (dec.)	Value (%)	Value (hex)	Time (sec.)	Value (dec.)	Value (%)	Value (hex)	Time (sec.)	Value (dec.)	Value (%)	Value (hex)
51.33	142	56	8E	102.77	95	37	5F	175.24	46	18	2E
52.24	141	55	8D	104.05	94	37	5E	176.92	45	18	2D
53.16	140	55	8C	105.35	93	36	5D	178.61	44	17	2C
54.09	139	55	8H	106.65	92	36	5C	180.30	43	17	2B
55.02	138	54	8A	107.96	91	36	5B	182.01	42	16	2A
55.96v	137	54	89	109.28	90	35	5A	183.72	41	16	29
56.91	136	53	88	110.61	89	35	59	185.44	40	16	28
57.87	135	53	87	111.94	88	35	58	187.17	39	15	27
58.84	134	53	86	113.28	87	34	57	188.90	38	15	26
59.81	133	52	85	114.63	86	34	56	190.65	37	15	25
60.79	132	52	84	115.99	85	33	55	192.40	36	14	24
61.78	131	51	83	117.36	84	33	54	194.16	35	14	23
62.78	130	51	82	118.73	83	33	53	195.92	34	13	22
63.79	129	51	81	120.12	82	32	52	197.70	33	13	21
64.80	128	50	80	121.5v	81	32	51	199.48	32	13	20
65.82	127	50	7F	122.91	80	31	50	201.28	31	12	1F
66.85	126	49	7E	124.31	79	31	4F	203.08	30	12	1E
67.89	125	49	7D	125.73	78	31	4E	204.88	29	11	1D
68.94	124	49	7C	127.15	77	30	4D	206.70	28	11	1C
69.99	123	48	7B	128.58	76	30	4C	208.52	27	11	1B
71.05	122	48	7A	130.02	75	29	4B	210.36	26	10	1A
72.13	121	47	79	134.39	72	28	48	212.19	25	10	19
73.20	120	47	78	135.86	71	28	47	214.04	24	9	18
74.29	119	47	77	137.34	70	27	46	215.90	23	9	17
75.38	118	46	76	138.82	69	27	45	217.76	22	9	16
76.49	117	46	75	140.32	68	27	44	219.63	21	8	15
77.60	116	45	74	141.82	67	26	43	221.51	20	8	14
78.71	115	45	73	143.33	66	26	42	223.40	19	7	13
79.84	114	45	72	144.85	65	25	41	225.30	18	7	12
80.98	113	44	71	146.38	64	25	40	227.20	17	7	11
82.12	112	44	70	147.92	63	25	3F	229.11	16	6	10
83.27	111	44	6F	149.46	62	24	3E	231.03	15	6	0F
84.43	110	43	6E	151.01	61	24	3D	232.96	14	5	0E
85.59	109	43	6D	152.57	60	24	3C	234.90	13	5	0D
86.77	108	42	6C	154.14	59	23	3B	236.84	12	5	0C
87.95	107	42	6B	155.71	58	23	3A	238.79	11	4	0B
89.14	106	42	6A	157.30	57	22	39	240.75	10	4	0A
90.34	105	41	69	158.89	56	22	38	242.72	9	4	09
91.55	104	41	68	160.49	55	22	37	244.70	8	3	08
92.76	103	40	67	162.09	54	21	36	246.68	7	3	07
93.98	102	40	66	163.71	53	21	35	248.68	6	2	06
95.21	101	40	65	165.33	52	20	34	250.68	5	2	05
96.45	100	39	64	166.96	51	20	33	246.68	7	3	07
97.70	99	39	63	168.60	50	20	32	248.68	6	2	06
98.95	98	38	62	170.25	49	19	31	250.68	5	2	05
100.22	97	38	61	171.91	48	19	30	252.68	4	2	04
101.49	96	38	60	173.57	47	18	2F				