

iSolution

Your integrated Solution

DMX512

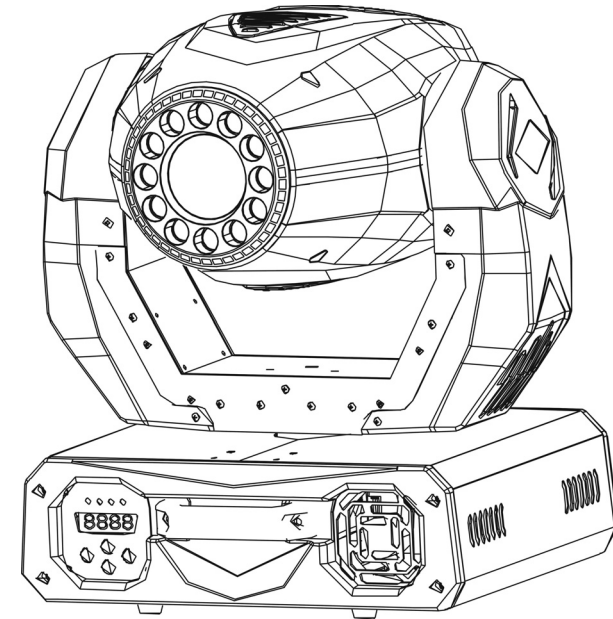

IM-250SW

User Guide

Please read these instructions carefully before use

Innovation , Quality , Performance

TABLE OF CONTENTS

1.Safety Instruction

2.Technical Specification

3.Lamp

4.How To Set The Unit

4.1 Control Panel

4.2 Main Function

4.3 Home Position Adjustment

5.How To Control The Unit

5.1 Master/Slave Built-In Preprogrammed Function

5.2 Easy Controller

5.3 DMX Controller

5.4 DMX 512 Configuration

5.5 DMX 512 Connection

6.Troubleshooting

7.Maintenance and Cleaning

1. Safety Instruction



WARNING

Please read carefully the instruction, which includes important information about the installation, usage and maintenance.

- Please keep this User Guide for future consultation. If you sell the unit to another user, be sure that they also receive this instruction booklet.
- Unpack and check carefully there is no transportation damage before using the unit.
- Before operating, ensure that the voltage and frequency of power supply match the power requirements of the unit.
- It's important to ground the yellow/green conductor to earth in order to avoid electric shock.
- The unit is for indoor use only. Use only in a dry location.
- The unit must be installed in a location with adequate ventilation, at least 50cm from adjacent surfaces. Be sure that no ventilation slots are blocked.
- Disconnect main power before fuse/lamp replacement or servicing.
- Replace fuse/lamp only with the same type.
- Make sure there are no flammable materials close to the unit while operating, as it is fire hazard.
- Use safety chain when fixes this unit. Don't handle the unit by taking its head only, but always by taking its base.
- Maximum ambient temperature is $T_a : 40^{\circ}\text{C}$. Don't operate it where the temperature is higher than this.
- Unit surface temperature may reach up to 85°C . Don't touch the housing bare-hand during its operation, and allow about 15 minutes to cool down before replacing bulb or serving, as the unit could be very hot.
- In the event of serious operating problem, stop using the unit immediately. Never try to repair the unit by yourself. Repairs carried out by unskilled people can lead to damage or malfunction. Please contact the nearest authorized technical assistance center. Always use the same type spare parts.
- Don't connect the device to any dimmer pack.
- Do not touch any wire during operation as there might be a hazard of electric shock.

EC Declaration of Conformity

We declare that our products (lighting equipments) comply with the following specification and bears CE mark in accordance with the provision of the Electromagnetic Compatibility (EMC) Directive 89/336/EEC.

EN 55103-1:1996, EN 55103-2:1996, EN 61000-3-2:2006,
EN 61000-3-3:1995+A1:2001+A2:2005

&

Harmonized Standard

EN 60598-2-17:1989+A2:1991, EN 60598-1:2008
EN62471:2008

Part 1:General requirements and test

Following the provisions of the low voltage directive 73/23/EEC and 93/68/EEC

7. Maintenance and Cleaning

Maintenance:

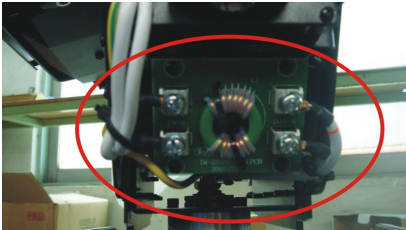

Anti-interference plate

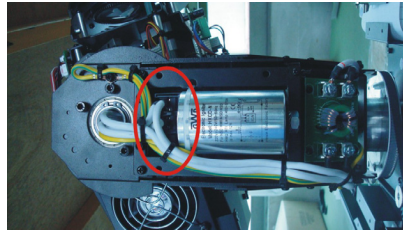

Ignitor

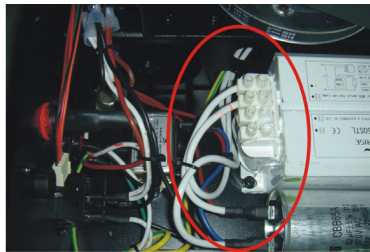

Ballast

- A. As the pictures shown above, if the cable or cable joints turned yellow or black, please replace the cable or cable joints immediately.
- B. Do maintain the fixtures every two months and make sure that all the screws and terminals have been locked firmly to make sure the normal performance of the fixtures. Negligence of maintenance would cause malfunction of the fixture.

Cleaning:

The cleaning of internal and external optical lenses and/or mirrors must be carried out periodically to optimize light output. Cleaning frequency depends on the environment in which the fixture operates: damp, smoky or particularly dirty surrounding can cause greater accumulation of dirt on the unit's optics.

- Clean with soft cloth using normal glass cleaning fluid.
- Always dry the parts carefully.
- Clean the external optics at least every 20 days. Clean the internal optics at least every 30/60 days.

Warning

- To prevent or reduce the risk of electrical shock or fire, do not expose the unit to rain or moisture.
- Never touch bulb with bare fingers, as it is very hot after using.
- Hot lamp explosion hazard. Do not open the unit within five minutes after switching off.
- Do not start on the unit without bulb enclosure or when housing is damaged.
- The housing, the lenses, or the ultraviolet filter must be replaced if they are visibly damaged.
- Do not look directly at the light while the bulb is on.

Caution

There are no user serviceable parts inside the unit. Do not open the housing or attempt any repairs by yourself. In the unlikely event your unit may require service, please contact your nearest dealer.

Installation

The unit should be mounted via its screw holes on the bracket (please refer to the drawing below). Always ensure that the unit is firmly fixed to avoid vibration and slipping while operating. Always ensure that the structure to which you are attaching the unit is secure and is able to support a weight of 10 times of the unit's weight. Also always use a safety cable that can hold 12 times of the weight of the unit when installing the fixture.

The equipment must be fixed by professionals. And it must be fixed at a place where is out of the touch of people and has no one pass by or under it.

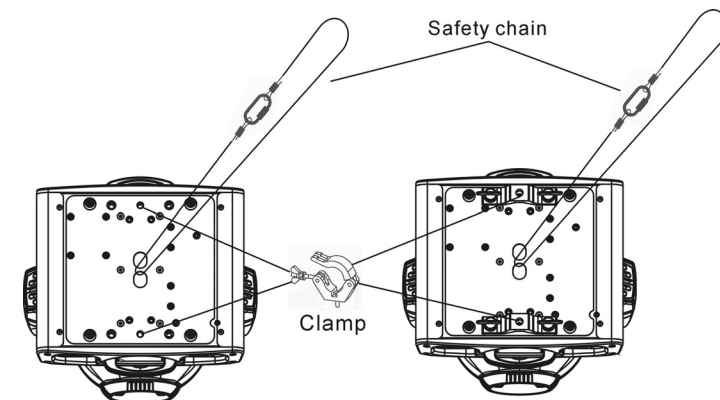

2. Technical Specification

Power supply

- AC 120V~60Hz or AC 230/240/250V~50/60Hz

Light Source

- MSD 250W/ NSD 250/2 W
- LED: Total 12pcs, Red: 4pcs, Green: 4pcs, Blue: 4pcs

Optical system

- High efficiency optical system
- High quality optical lens and dichroic colors
- Beam angle: 13°

Shutter/Dimmer

- Blackout, 0~100 smooth dimming and strobe speed variable(1~10 flashes per second).

Color wheel

- Independent color wheel with 9 trapezoid dichroic colors plus white.
- Color wheel rotates with variable speed, giving rainbow effect.

Gobo wheel

- Independent gobo wheel with 7 rotating, interchangeable gobos plus open: 5 metal gobos, 2 glass gobos are included.
- Gobo wheel rotates with variable speed, giving shaking effect.

Effect Wheel

- Prism/Rotating Prism

Movement

- Pan: 540° in 2.8 second.
- Tilt: 270° in 1.6 second.

DMX Channels

Channel 1 = Pan	Channel 12 = Prism Rotation
Channel 2 = Tilt	Channel 13 = Focus
Channel 3 = Pan/Tilt Speed selection	Channel 14 = Pan 16 bit
Channel 4 = Dimmer	Channel 15 = Tilt 16 bit
Channel 5 = Shutter/Shaking	Channel 16 = Reset/Lamp on/off
Channel 6 = Color	Channel 17 = Red LED
Channel 7 = No Function	Channel 18 = Green LED
Channel 8 = No Function	Channel 19 = Blue LED
Channel 9 = Gobo	Channel 20 = LED Color Macro
Channel 10 = Gobo Rotation	Channel 21 = Dimmer/Strobe
Channel 11 = Prism	

Pay attention to the belt tension when install the belt.

Please refer to the photos below:

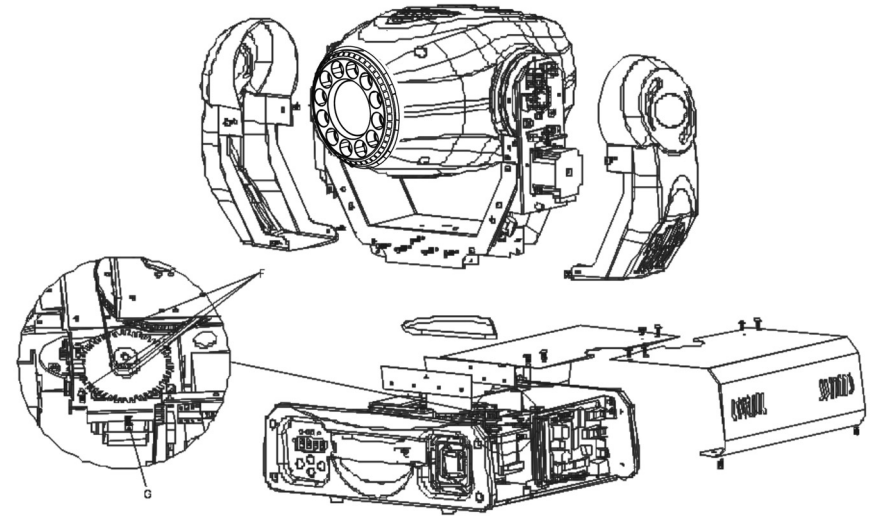
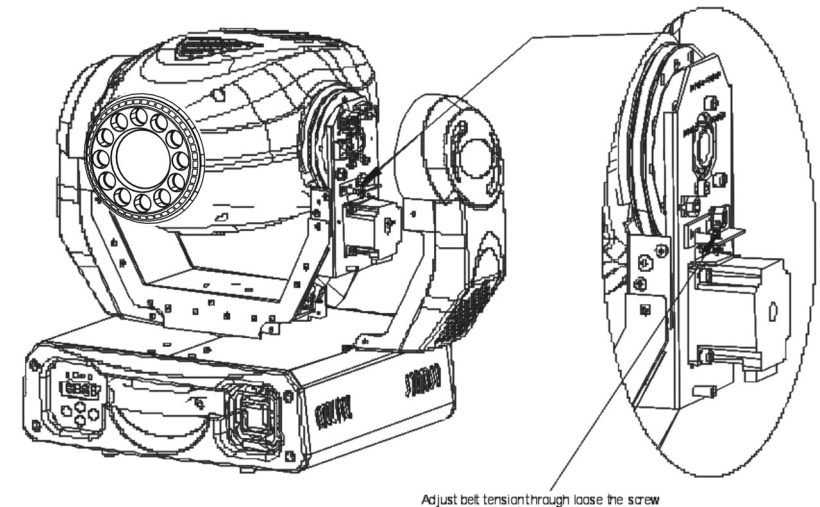

Photo 1



Adjust belt tension through loose the screw

Photo 2

F. If The tilt belt is broken

1. Turn off the main power.
2. Unscrew all the screws (A) and open the right arm cover (B).
3. Unscrew the screws (C), the screws (D) and screws (E) that fix the bridge.
4. Change a new belt (F). Please adjust the tension of the belt properly. Note: do not fix belt too tight as it is easy to rupture.
5. Reverse the procedures from point 3 to 2.

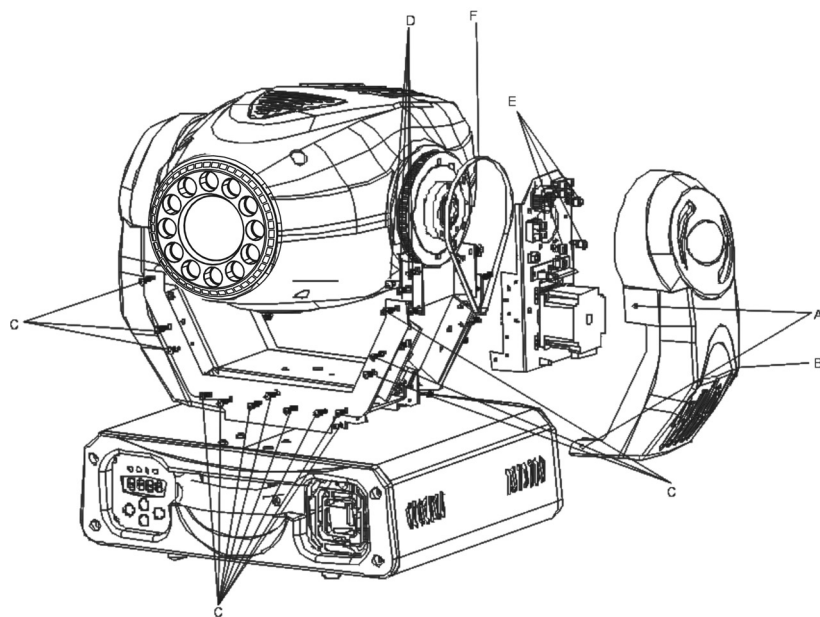

Luminous intensity:

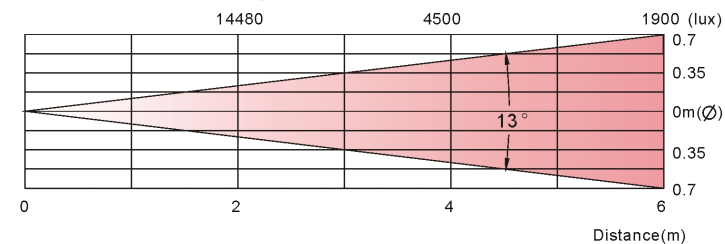

Dimension: 428 x 369 x 466 mm (L x W x H)

Weight: 23 kg

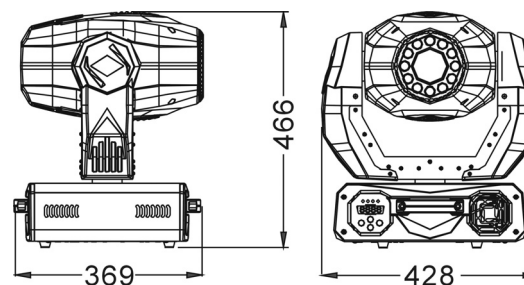

2.1. Inserting/Exchanging rotating gobos

DANGER!

Install the gobos with the device switched off only.

Unplug from mains before changing gobos!

Open the cover by loosening the fastening screw at the sides of the cover.

If you wish to use other forms and patterns as the standard-gobos, or if the gobos are to be exchanged, remove the fixation ring with an appropriate tool. Remove the gobo and insert the new gobo. Press the fixation-ring together and insert it in the front of the gobo.

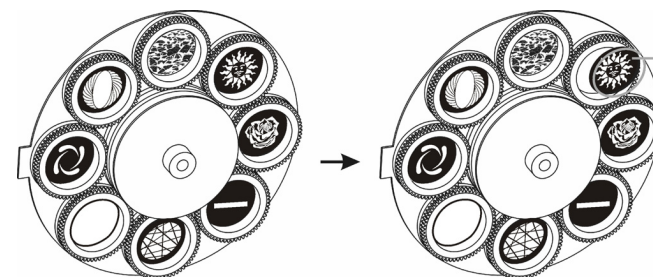

CAUTION!

Never unscrew the screws of the rotating gobo as the ball bearing will otherwise be opened!

3. Lamp



WARNING

In case of replacement of the lamp or maintenance, do not open the fixture within 15 minutes until the unit cools down after switching off.

Because of its high internal pressure, there might be a risk that the Discharge lamp would explode during operation. The lamp emits intense UV radiation which is harmful to the eyes and skin. The high luminance of the arc can cause severe damage to the retina if looks directly at the lamp.

MSD 250W/ NSD 250/2 W

1. Always switch off the main supply and never handle the lamp or luminaire when it is hot.
2. Do not touch the bulb with bare hands. If this happens, clean the lamp with denatured alcohol and wipe it with a lint free cloth before installation.
3. The lamp generates UV radiation. Never operate the lamp without appropriate shielding.
4. When burning, the lamp operates at high pressure and there is a slight risk of arc tube rupture. The risk increases with age, temperature and improper handling of the lamp. Do not use the lamp any longer than its specified life.
5. Make sure the lamp is located in the center of the reflector for the best spot.

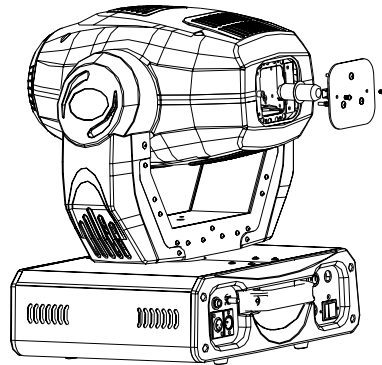

G. If The pan belt is broken

1. Turn off the main power.
2. Unscrew all the screws (A) and open the base-housing cover (B).
3. Unscrew all the screws (C) and open the arm cover (D).
4. Unplug all the connect wires that from the arm to the bottom.
5. Unscrew the screws (E) and remove the fixture head.
6. Loose the screws (F), then loose the screws (G).
7. Change a new belt (H) , put the belt around the axis gear and motor gear.
8. Screwed the screws (G), install the new belt and adjust the belt tension properly. Note: do not fix belt too tight as it is easy to rupture.
9. Plug all the connect wires back that form the bottom to the arm.
10. Reverse the procedures from point 5 to point 2.

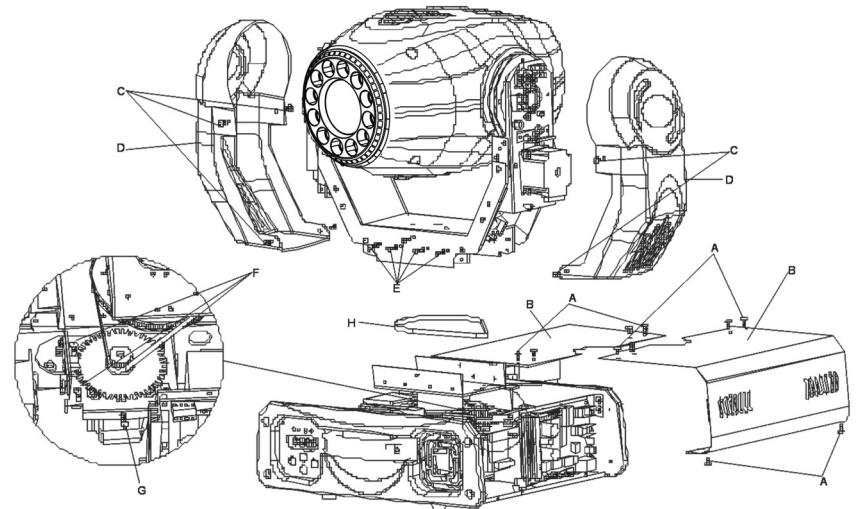

6. Troubleshooting

Following are a few common problems that may occur during operation. Here are some suggestions for easy troubleshooting:

A. The unit does not work, no light and the fan does not work

1. Check the connect power and main fuse.
2. Measure the mains voltage on the main connector.
3. Check the power on LED.

B. Not responding to DMX controller

1. DMX LED should be on. If not, check DMX connectors, cables to see if link properly.
2. If the DMX LED is on and no response to the channel, check the address settings and DMX polarity.
3. If you have intermittent DMX signal problems, check the pins on connectors or on PCB of the unit or the previous one.
4. Try to use another DMX controller.
5. Check to see if the DMX cables run near or run alongside to high voltage cables that may cause damage or interference to DMX interface circuit.

C. Some units don't respond to the easy controller

1. You may have a break in the DMX cabling. Check the LED for the response of the master/slave mode signal.
2. Wrong DMX address in the unit. Set the proper address.

D. No response to the sound

1. Make sure the unit is not receiving DMX signal.
2. Check microphone to see if it is good by tapping the microphone.

E. One of the channels is not working well

1. The stepper motor might be damaged or the cable connected to the PCB is broken.
2. The motor's drive IC on the PCB might be out of condition.

F. The lamp is cutting out intermittently

1. The lamp is not working well. Check the main voltage either too high or too low.
2. Internal temperature may be too high. Check and if necessary replace the fan on the head.

4. How To Set The Unit

4.1. Control Panel

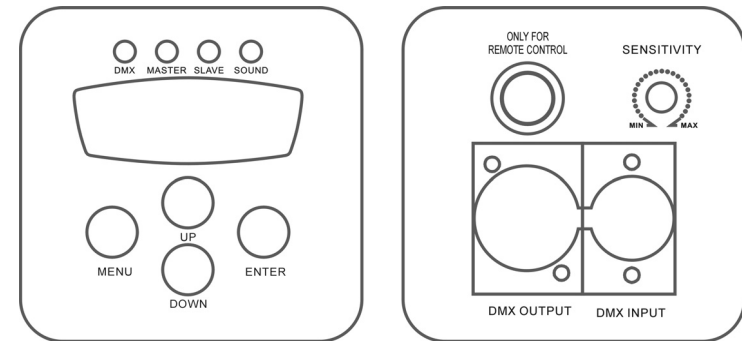

Display

To show the various menus and the selected functions

LED

DMX	On	DMX input present
MASTER	On	Master mode
SLAVE	On	Slave mode
SOUND	Flashing	Sound activation

Button

MENU	To select the programming functions
DOWN	To go backward in the selected functions
UP	To go forward in the selected functions
ENTER	To confirm the selected functions

Remote controller input

By connecting to CA-8 to control the unit for Stand by, Function, and Mode function.

Sensitivity

To adjust the sound-input sensitivity

DMX input/output

For DMX512 operation, use 3-pin XLR plug cable to link the unit together.

4.2. Main Function

To select any of the pre-set functions, press the **MENU** button up to when the required one is shown on the display. Select the function by **ENTER** button and the display will blink. Use **DOWN** and **UP** button to change the mode. Once the required mode has been selected, press the **ENTER** button to setup or it will automatically return to the main functions without any change after idling 8 seconds. To go back to the functions without any change press the **MENU** button. The main functions are shown below:

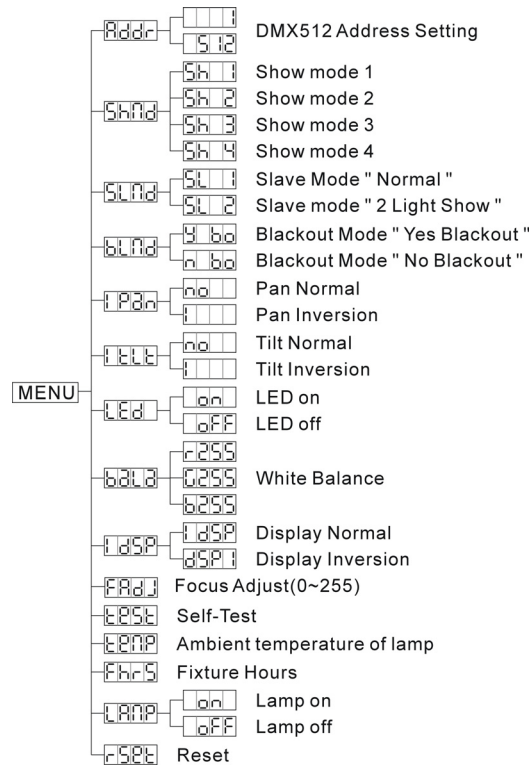

Addr

DMX512 Address Setting

Press the **MENU** button up to when the **Addr** is shown on the display. Pressing **ENTER** button and the display will blink. Use **DOWN** and **UP** button to change the DMX512 address. Once the address has been selected, press the **ENTER** button to setup. Idling 8 seconds automatically exit menu mode. Back to the functions without any change press **MENU** button.

5.5. DMX512 Connection

The DMX512 is widely used in intelligent lighting control, with a maximum of 512 channels.

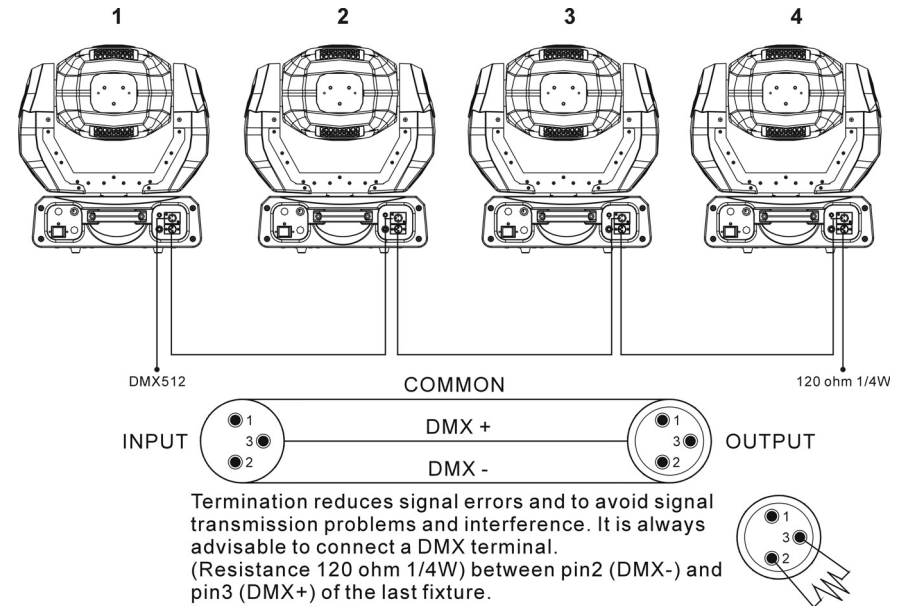

1. If you use a controller with 5 pins DMX connector, you need to use a 5 to 3 pin adapter.
2. At last unit, the DMX cable has to be terminated with a terminator. Solder a 120-ohm 1/4W resistor between pin 2(DMX-) and pin 3(DMX+) into a 3-pin XLR-plug and plug it in the DMX-output of the last unit.
3. Connect the unit together in a "daisy chain" by XLR plug cable from the output of the unit to the input of the next unit. The cable cannot be branched or split to a "Y" cable. DMX512 is a very high-speed signal. Inadequate or damaged cables, soldered joints or corroded connectors can easily distort the signal and shut down the system.
4. The DMX output and input connectors are pass-through to maintain the DMX circuit, when power is disconnected to the unit.
5. Each lighting unit needs to have an address set to receive the data sent by the controller. The address number is between 0-511 (usually 0 & 1 are equal to 1).
6. The end of the DMX512 system should be terminated to reduce signal errors.
7. 3 pin XLR connectors are more popular than 5 pins XLR.
3 pin XLR: Pin 1: GND, Pin 2: Negative signal (-), Pin 3: Positive signal (+)
5 pin XLR: Pin 1: GND, Pin 2: Negative signal (-), Pin 3: Positive signal (+)

DMX 512 Configuration				
Channel 17	Channel 18	Channel 19	Channel 20	Channel 21
Red ELD	Green LED	Blue LED	LED Color	Dimmer/Strobe
			248-255 Color 31 240-247 Color 30 232-239 Color 29 224-231 Color 28 216-223 Color 27 208-215 Color 26 200-207 Color 25 192-199 Color 24 184-191 Color 23 176-183 Color 22 168-175 Color 21 160-167 Color 20 152-159 Color 19 144-151 Color 18 136-143 Color 17 128-135 Color 16 120-127 Color 15 112-119 Color 14 104-111 Color 13 096-103 Color 12 088-095 Color 11 080-087 Color 10 072-079 Color 9 064-071 Color 8 056-063 Color 7 048-055 Color 6 040-047 Color 5 032-039 Color 4 024-031 Color 3 016-023 Color 2 008-015 Color 1 000-007 OFF	

i.) For DMX reset, put DMX value of CH-8 & CH-16 to 255, the unit will reset after about five seconds.

For lamp on, put DMX value of CH-8 to 247 & CH-16 to 255.

For lamp off, put DMX value of CH-8 to 239 & CH-16 to 255.

ii.) For color sound activated, put DMX value of CH-6 to 248-255.

For gobo sound activated, put DMX value of CH-9 to 248-255.

SH0d Show Mode

Press the **MENU** button up to when the SH0d is showing on the display. Pressing **ENTER** button and the display will blink. Use **DOWN** and **UP** button to select the SL01 (show 1) or SH 2 (show 2) or SH 3 (show 3) or SH 4 (show 4) mode. Once the mode has been selected, press the **ENTER** button to setup. Idling 8 seconds automatically exit menu mode. Back to the functions without any change press **MENU** button.

SH 1 Show 1 mode - Fixture is placed on the floor. Tilt movement angle 210°.

SH 2 Show 2 mode - Fixture is fixed under ceiling. Tilt movement angle 90°.

SH 3 Show 3 mode - Fixture is placed on the speaker, The spot is always projecting to the audience's direction; i.e in front of the stage. Pan movement angle (left to right to left): 160°. Tilt movement angle: 90° (60° above horizon; 30° below horizon).

SH 4 Show 4 mode - Fixture is fixed under ceiling. The spot is mainly projecting in front of the stage. Pan movement angle (left to right to left) :160°. Tilt movement angle: 90° (vertically, front 75°; back 15°) .

SL0d Slave Mode



Press the **MENU** button up to when the SL0d is shown on the display. Pressing **ENTER** button and the display will blink. Use **DOWN** and **UP** button to select the SL01 (normal) or SL 2 (2 light show) mode. Once the mode has been selected, press the **ENTER** button to setup. Idling 8 seconds automatically exit menu mode. Back to the functions without any change press **MENU** button.

BL0d Blackout Mode



Press the **MENU** button up to when the BL0d is shown on the display. Pressing **ENTER** button and the display will blink. Use **DOWN** and **UP** button to select the Y ba (yes blackout) or n ba (no blackout) mode. Once the mode has been selected, press the **ENTER** button to setup. Idling 8 seconds automatically exit menu mode. Back to the functions without any change press **MENU** button.

IP2n Pan Inversion



Press the **MENU** button up to when the IP2n is shown on the display. Pressing **ENTER**

button and the display will blink. Use **DOWN** and **UP** button to select the  (normal) or  (pan inversion) mode. Once the mode has been selected, press the **ENTER** button to setup. Idling 8 seconds automatically exit menu mode. Back to the functions without any change press **MENU** button.



 Tilt Inversion

Press the **MENU** button up to when the  is shown on the display. Pressing **ENTER** button and the display will blink. Use **DOWN** and **UP** button to select the  (normal) or  (tilt inversion) mode. Once the mode has been selected, press the **ENTER** button to setup. Idling 8 seconds automatically exit menu mode. Back to the functions without any change press **MENU** button.



 Led Display

Press the **MENU** button up to when the  is showing on the display. Pressing **ENTER** button and the display will blink. Use **DOWN** and **UP** button to select the  (Led on) or  (Led off) mode. Once the mode has been selected, press the **ENTER** button to setup. Idling 8 seconds automatically exit menu mode. Back to the functions without any change press **MENU** button.

 White Balance

Press the **MENU** button up to when the  is showing on the display. Pressing **ENTER** button and  will blink on the display, use **DOWN** and **UP** button to adjust the value from 125 to 255, press **ENTER** button to store and  will blink on the display, use **DOWN** and **UP** button to adjust the value from 125 to 255, press **ENTER** button to store. Idling 8 seconds automatically exit menu mode. Back to the functions without any change press **MENU** button.

 Display Inversion













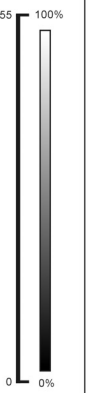

















It is good for you to install the unit on the floor or under ceiling. Press the **MENU** button up to when the  is blinking on the display. Use the **ENTER** button to change to the mode  (display inversion), It will automatically store after 8 seconds. Or press the **ENTER** button again return to the mode  (display normal). To go back to the functions press the **MENU** button.

Once the address has been selected, press and keep **ENTER** button pressed up to when the display stops blinking or storing automatically 8 seconds later. To go back to the functions without any change press the **MENU** button again.

Please refer to the following diagram to address your DMX512 channel for the first 4 units.

5.4. DMX 512 Configuration

DMX 512 Configuration							
Channel 1	Channel 2	Channel 3	Channel 4	Channel 5	Channel 6	Channel 7	Channel 8
Pan	Tilt	Pan/Tilt speed select	Dimmer	Shutter/Shaking	Color	No function	No function
 540°	 270°	 255 Slow	 255 100%	248-255 Open 240-247  239 Fast shaking  132 Slow shaking 131 Fast shutter  16 Slow shutter 008-015 Open 000-007 Blackout	248-255  247 Slow  188 Fast 187 Fast  128 Slow 115-127 Pink 102-114 Light green 089-101 UV purple 077-088 Blue 064-076 Red 051-063 Yellow 039-050 Light blue 026-038 Magenta 013-025 Green 000-012 White		
Channel 9	Channel 10	Channel 11	Channel 12	Channel 13	Channel 14	Channel 15	Channel 16
Gobo	Gobo Rotation	Prism	Prism Rotation	Focus	Pan 16 bit	Tilt 16 bit	Reset Lamp On/Off
248-255  247 Slow 188 Fast 187 Fast 128 Slow 112-127  096-111  080-095  064-079  048-063  032-047  016-031  000-015 	248-255 Stopped 245 Fast  135 Slow 121-134 Stopped 120 Slow  010 Fast 000-009 Stopped	171-255  Prism effect 2 086-170  Prism effect 1	248-255 Stopped 245 Fast  135 Slow 121-134 Stopped 120 Slow  010 Fast 000-009 Stopped	255   0 	255  16 BIT PAN	255  16 BIT TILT	255 Reset  0 Normal

5.1. Master/Slave Built-In Preprogrammed Function

Once you control the unit by Built-In program, be sure the unit is setting on **nlba** mode via menu.

By linking the units in master/slave connection, the first unit will control the other units to give an automatic, sound activated, synchronized light show. This function is good when you want an instant show. You have to select show (show 1, 2, 3, 4) modes for the first unit (master). Its DMX input jack will have nothing plugged into it, and its master LED will be constantly on and sound LED will flash to the music. The other units will have to set in slave mode **SLnd** and select **SL01** (normal) or **SL02** (2 light show) mode. Their DMX cables plugged into the DMX input jacks (daisy chain) and the slave LED lights will constantly on.

2-light show

In **SLnd** (slave mode), **SL01** means the unit works normally and **SL02** means 2-light show. In order to create a great light show, you can set **SL02** on the second unit to get contrast movement to each other, even if you have two units only.

5.2. Easy Controller

The easy remote control is used only in master/slave mode. By connecting to the 1/4" microphone jack of the first unit, you will find that the remote control on the first unit will control all the other units for Stand by, Function and Mode.

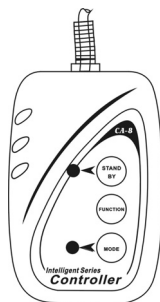

Stand by	Blackout the unit			
Function	Strobe 1. Color sync. strobe 2. Sync. strobe 3. Two-light strobe	X/Y moving show pattern selection (Show 1 ~ Show 4) Please refer to 4.2. Main Functions- Show mode	Gobo/Color selection 1.Hold on for gobo selection 2.Press for color change	X/Y moving setting 1.Macro(sound active) 2.Fade (sound invalid)
Mode	Sound 1 (LED off)	Sound 2 (LED slow blinking)	Slow/Sound 3 (LED on)	Position/ Latch (LED fast blinking)

5.3. DMX Controller

If you use a universal DMX controller to control the units, you have to set DMX address from 1 to 512 channel so that the units can receive DMX signal.

Press the **MENU** button up to when the **Addr** is shown on the display. Pressing **ENTER** button and the display will blink. Use **DOWN** and **UP** button to change the DMX512 address.

LDSP

Display normal mode for the fixture putting on the floor.

dSPI

Display inversion mode for the fixture fixing under ceiling.

FAdj

Focus Adjust

Press the **MENU** button up to when the **FAdj** is blinking on the display. Pressing **ENTER** button, the unit will focus on tilt 90°, and then the unit will focus on tilt 0°, pan 0°, pan 90°, pan 180°, pan 270° in every pressing **ENTER** button. To go back to the functions press the **MENU** button again.

tEst

Self-Test

Press the **MENU** button up to when the **tEst** is blinking on the display. Pressing **ENTER** button and the unit will run self-test by built-in program. To go back to the functions press the **MENU** button again.

tEMP

Ambient temperature of lamp

Press the **MENU** button up to when the **tEMP** is blinking on the display. Pressing **ENTER** button and the ambient temperature of lamp will show on the display. To go back to the functions press the **MENU** button again.

Fhrs

Fixture Hours

Press the **MENU** button up to when the **Fhrs** is blinking on the display. Pressing **ENTER** button and the display will show the number of working hours of the unit. To go back to the functions press the **MENU** button again.

LAMP

Lamp ON/OFF

Press the **MENU** button up to when the **LAMP** is blinking on the display. Pressing **ENTER** button and the display will blink. Use **DOWN** and **UP** button to select the **LON** (Lamp on) or **LOFF** (Lamp off) mode. Once the mode has been selected, press the **ENTER** button to setup. Idling 8 seconds automatically exit menu mode. Back to the functions without any change press **MENU** button.

rSet

Reset

Press the **MENU** button up to when the **rSet** is blinking on the display. Pressing **ENTER** button and all channels of the unit will return to their standard position. It will cost about 20

seconds and then automatically exit menu mode.

DMX RESET :

Set DMX value of channel 8 and channel 16 to 255, then all channels of the unit will return to their standard home position.

4.3 Home Position Adjustment

Press **MENU** button for at least 5 seconds into offset mode to adjust the home position, when you want to adjust pan and tilt home position, you should be run **FADJ** mode first , the functions are shown below:

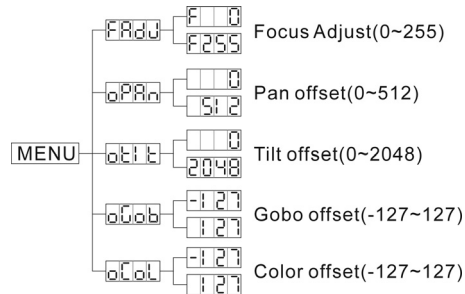

FADJ Focus Adjust

Press the **MENU** button for at least 5 seconds into offset mode, use **DOWN** and **UP** button up to when the **FADJ** is shown on the display. Pressing **ENTER** button, the unit will focus on the center position. Use **DOWN** and **UP** button to adjust focus, this settings only for offset mode to adjust home position. To go back to the main functions without any change after 8 seconds

OPAN Pan offset

Press the **MENU** button for at least 5 seconds into offset mode, use **DOWN** and **UP** button up to when the **OPAN** is shown on the display. Pressing **ENTER** button and the display will blink. Use **DOWN** and **UP** button to adjust the pan home position. Once the position has been selected, press the **ENTER** button to setup or automatically return to the offset functions without any change press the **MENU** button again, To go back to the main functions without any change after 8 seconds.

OTILT Tilt offset

Press the **MENU** button for at least 5 seconds into offset mode, use **DOWN** and **UP** button

up to when the **OTILT** is shown on the display. Pressing **ENTER** button and the display will blink. Use **DOWN** and **UP** button to adjust the tilt home position. Once the position has been selected, press the **ENTER** button to setup or automatically return to the offset functions without any change press the **MENU** button again, To go back to the main functions without any change after 8 seconds.

OGOB Gobo offset

Press the **MENU** button for at least 5 seconds into offset mode, use **DOWN** and **UP** button up to when the **OGOB** is shown on the display. Pressing **ENTER** button and the display will blink. Use **DOWN** and **UP** button to adjust the gobo home position. Once the gobo has been selected, press the **ENTER** button to setup or automatically return to the offset functions without any change press the **MENU** button again, To go back to the main functions without any change after 8 seconds.

OCOL Color offset

Press the **MENU** button for at least 5 seconds into offset mode, use **DOWN** and **UP** button up to when the **OCOL** is shown on the display. Pressing **ENTER** button and the display will blink. Use **DOWN** and **UP** button to adjust the color home position. Once the color has been selected, press the **ENTER** button to setup or automatically return to the offset functions without any change press the **MENU** button again, To go back to the main functions without any change after 8 seconds.

5. How To Control The Unit

You can operate the unit in three ways:

1. By master/slave built-in preprogrammed function
2. By easy controller
3. By universal DMX controller

No need to turn the unit off when you change the DMX address, as new DMX address setting will be effected at once. Every time you turn the unit on, it will show I250 on the display and move all the motors to their 'home' position and you may hear some noises for about 20 seconds. After that the unit will be ready to receive DMX signal or run the built-in programs.